



SKI RACING AUSTRALIA (SRA) RULE BOOK
SEASON 2011 – 2012

CONTENTS

1. DEFINITIONS AND/OR INTERPRETATIONS.....	10
2. GENERAL.....	12
2.1. Guidelines and Application of the Rules. Includes references to the Code of Conduct, Drug Policy and Conditions of Sanctioning.	12
2.2. Interpretation of the Rules	12
2.3. Application of Rules.....	12
2.4. Exception to the Rules	12
2.5. Rule Book to be reissued at Beginning of each Season.	13
2.6. Amendments.....	13
2.7. Non-Conformity with Rules	13
2.8. Conducting an Sanctioned Event and Compliance with the Conditions of Sanctioning .	13
2.9. Advertising of the Event.....	14
2.10. Applicable Rules.....	14
2.11. Schedule of Events	14
2.12. Calendar of Sanctioned Events.....	14
2.13. Schedule Changes.....	14
2.14. Sportsmanlike Manner	15
3. RESPONSIBILITY OF OFFICIALS & APPEAL PROCESSES	15
3.1. Chief Judge.....	15
3.2. Judges.....	16
3.3. Appointment of Jury for Disagreements.....	16
3.4. Grounds for an Appeal	16
3.5. Appeals.....	17
3.6. Official Timing	17
3.7. Role of the Race Committee.....	17



SKI RACING AUSTRALIA (SRA) RULE BOOK
SEASON 2011 – 2012

3.8.	Duties and Responsibilities of the Race Committee	18
3.9.	Conflict of Interest	19
3.10.	Race Day Report	19
3.11.	Boat Log Book & Race Day Book.....	19
3.12.	Fuel (refer 9.14 Fuels).....	20
3.13.	Incident Report Form to be completed	20
4.	SCORING OF EVENTS AND POINTS AWARD.....	20
4.1.	Scoring	20
4.2.	Point Scoring	21
5.	INFRINGEMENTS & PROTESTS.....	21
5.1.	Protests.....	21
5.2.	Resolution of Protest.....	22
5.3.	Notification of Results.....	22
5.4.	Error in Results.....	22
5.5.	Disqualifications and Penalties	22
5.6.	Disqualification	23
5.7.	Serious Contravention of the Rules	24
5.8.	Summary Judgement.....	24
5.9.	Exclusions from Events	24
6.	COMPETITION REQUIREMENTS.....	24
6.1.	Drugs and Alcohol.....	24
6.2.	Competition Divisions, Age of Competitors, Maximum Boat Litres & Social Class Rules	26
6.3.	Novice Classes	27
6.4.	Social Class	27
6.5.	Social Class Ropes.....	27
6.6.	Social Class Skis	27



SKI RACING AUSTRALIA (SRA) RULE BOOK
SEASON 2011 – 2012

6.7.	Outboard Classes	28
6.8.	Inboard Classes	29
6.9.	Super Class	29
6.10.	60 mph Class.....	29
6.11.	70 mph Class.....	31
6.12.	Substitutions	32
6.13.	Guidelines for Events other than Australian Speed and Marathon Championships	32
6.14.	Definition of Novice Skier.....	33
6.15.	Crew to Wear Full Race Gear	33
7.	GENERAL BOAT REQUIREMENTS AND SAFETY	34
7.1.	Boat Safety Inspection	34
7.2.	Boat & Equipment Inspection Prior to or During an Event	34
7.3.	Non-Compliance with the Rules	34
7.4.	Vessels to be registered	34
7.5.	Compliance with Authority Requirements and/or Regulations.....	35
7.6.	Vessel to be registered with SRA	35
7.7.	Vessel Structural State	35
7.8.	Vessel Design	35
7.9.	Restrictions to Boat Names & Associated Materials.....	35
7.10.	Towing Cleat or Eye, or Sampson Post	36
7.11.	Painter/Tow Lines (if fitted).....	36
7.12.	Sharp Edges.....	36
7.13.	Windshield.....	36
7.14.	Steering Gear.....	36
7.15.	Steering Relating to Inboard Classes	39
7.16.	Crack Testing of Rudders	39
7.17.	Inboards and Outboards welded or repaired below the Cavitation Plate Line.....	40

**SKI RACING AUSTRALIA (SRA) RULE BOOK
SEASON 2011 – 2012**

7.18. Control Cables.....	40
7.19. Fuel Tanks	40
7.20. Fuel Lines.....	40
7.21. Throttles and Carburettors.....	41
7.22. Extinguisher System	41
7.23. Items to be secured.....	41
7.24. Battery Storage.....	41
7.25. Propellers.....	42
7.26. Propeller Shaft	42
7.27. Refer Rule 7.39.....	43
7.28. Buoyancy.....	43
7.29. Seating.....	43
7.30. Cut Out Switch (Jack Plug).....	43
7.31. Official Race Numbers	44
7.32. Safety Flag	45
7.33. V-Sheets and Blue and White Medical Flag	45
7.34. Distress Flares	45
7.35. Paddle.....	46
7.36. Handholds.....	46
7.37. Footrest	46
7.38. Engine Mountings, Transmissions and Lifts for Outboards.....	46
7.39. Inboards Requirements	47
7.40. Engine Condition	47
7.41. Exhaust Systems.....	47
7.42. Anchor (if required).....	47
7.43. Anchor Line (if required)	48
7.44. Compasses (if required).....	48
7.45. Bilge Pump.....	48

**SKI RACING AUSTRALIA (SRA) RULE BOOK
SEASON 2011 – 2012**

7.46. Engine Wells.....	48
7.47. Dry Land Engine Testing	49
8. CREW AND COMPETITOR REQUIREMENTS AND SAFETY	49
8.1. Eligibility to Compete	49
8.2. Competing Team or Crew	49
8.3. Crew Members of the Boat	49
8.4. Helmets	49
8.5. Wearing of Race Gear Following Event.....	50
8.6. Life Jackets	50
8.7. Footwear	51
8.8. Fire Suits.....	51
8.9. Boat Testing and Unofficial Practice.....	51
8.10. First Aid Awareness.....	51
8.11. Safety Belts	51
8.12. Boat Drivers and Observers.....	51
8.13. Skiers.....	52
8.14. Helmets to be worn on race day and practice.....	52
8.15. Buoyancy Vests	53
8.16. Use of Water Bottles and the like.....	54
8.17. Clinch Gloves.....	54
8.18. Taping of Ski Bindings	54
8.19. Skis	55
8.20. Marathon Skis	55
8.21. Non-conformity with the Rules	56
8.22. Tow Lines.....	56
9. BOAT TECHNICAL REQUIREMENTS.....	56
9.1. Boat Measurements	56



SKI RACING AUSTRALIA (SRA) RULE BOOK
SEASON 2011 – 2012

9.2.	Measuring and Sealing of Engines.....	60
9.3.	Modifications.....	60
9.4.	Stock Inboard Rules	60
9.5.	Single Engine Outboard	64
9.6.	200Hp Outboard	64
9.7.	S.M.O.C. – Standard Motor Open Cockpit	65
9.8.	M.O.C. – Modified Open Cockpit	65
9.9.	Definition of a Standard Outboard	66
9.9.1	Engines Manufactured in 2000 and prior	66
9.9.2	Engines Manufactured in 2001 and onwards	68
9.10.	Definition of an Open Cockpit Hull.....	70
9.11.	Post Race Technical Scrutineering	70
9.12.	Engine Scrutineering Stipulations.....	71
9.13.	Gas jets or Rockets.....	71
9.14.	Fuels	72
10.	COMPETITION AREA	72
10.1.	Course	72
10.2.	Buoy Colour Code.....	73
11.	CONDUCT IN COMPETITION AREA	73
11.1.	Governing Rules.....	73
11.2.	Safety Precautions.....	73
11.3.	Breakdown or Equipment Failure.....	74
11.4.	Skier Entering Boat during Competition.....	74
11.5.	Fastening of Towline or Handle/s	74
11.6.	Connection to Tow Line	75
11.7.	Entries	75
11.8.	Order of Contestants	75



SKI RACING AUSTRALIA (SRA) RULE BOOK
SEASON 2011 – 2012

11.9. Official Start Method.....	75
11.10. Grid Start.....	76
11.11. Simultaneous Mass Starts	76
11.12. Ski Racing Events - Interval Starts.....	76
11.13. Briefing of Competitors	76
11.14. Start.....	76
11.15. Tow lines	77
11.16. Whipping of Skier/s and Unsuccessful Starts	77
11.17. Lifting of Boats.....	77
11.18. Drivers to Look Forward	77
11.19. Observers Duty.....	77
11.20. Skiing Position/A Fall	78
11.21. Passing in a Distance Race	78
11.22. Passing Applicable to All Events Unless Noted Otherwise.....	79
11.23. Failure to Complete Course	79
11.24. Skiers to use Same Number of Skis	79
11.25. Finish.....	80
11.26. Drop-off area and Use of the Chequered Flag.....	80
12. SKI RACING EVENTS	80
12.1. Definition	80
13. MARATHONS	80
13.1. Course and Order of Skis.....	80
13.2. One Skier Only for Event.....	81
13.3. Changeover Area and Course.....	81
13.4. Finish Time at Judges Discretion.....	81
13.5. Australian Marathon Championships.....	81



SKI RACING AUSTRALIA (SRA) RULE BOOK
SEASON 2011 – 2012

14. AUSTRALIAN SPEED & MARATHON CHAMPIONSHIPS	81
14.1. Race Committee	81
14.2. Rescue Services.....	82
14.3. Communications	82
14.4. Events and Times for Australian Speed & Marathon Championships.....	82
14.5. Restrictions Applicable to Australian Speed and Marathon Championships	83
14.6. Additional Rules.....	83
14.7. Events Stopped with less than 50% completed	83
14.8. Eligibility to Enter Australian Speed and Marathon Championships	83
14.9. Appointment of the Chief Judge, Assistant Chief Judge, Calculator and Judges	83
14.10. Appointment of Adjudicator.....	84
14.11. Team Captains	84
14.12. Lane Racing.....	84
15. RELAYS AND CLUB RACING	84
15.1. Relays and Club Racing	84
16. CIRCUIT RACING (GRAND PRIX TYPE RACING) (INTERNATIONAL WATER SKI FEDERATION).....	84
16.1. Starting Distance.....	84
16.2. Simultaneous Mass Start Procedure	85
16.3. Timing	85
16.4. Placing to be determined by the Skier/s Time	85
16.5. Finish.....	86
16.6. Turns, Passing and Changing Course	86
16.7. No Crowding or Forcing a Passage	86
16.8. Distance between competing Boats.....	86
16.9. Procedure to be followed after a Fall	86
16.10. Distance required before Boat can Cut-in	87



**SKI RACING AUSTRALIA (SRA) RULE BOOK
SEASON 2011 – 2012**

16.11. Distance required when following a Skier	87
16.12. Closed Circuit Racing.....	87
16.13. Competitors to Give Way	87
16.14. Required Flags and their Meanings	87
17. WORLDS COMPETITION.....	88
17.1. Selection of Australian Team Members to compete at World Water Ski Racing Championships	88
17.2. Skier Eligibility to Compete at the World Water Ski Racing Championships.....	89
17.3. SRA Selection Policy.....	89
18. SKI RACING AUSTRALIA CODE OF CONDUCT FOR MEMBERS. 90	
FORMULA 2 RULES, AS PER IWWF RULE BOOK.	96
AMENDMENTS PAGE.....	97

SKI RACING AUSTRALIA (SRA) RULE BOOK
SEASON 2011 – 2012

1. DEFINITIONS and/or INTERPRETATIONS

- **“Boat Log Book & Race Day Book”** is the book issued following receipt of all documentation received by SRA office. This book will be provided to every boat owner and must be kept with the boat, at all times. Upon request, this book must be made available to an SRA official.
- **“Body”** includes the Local, State, Region or Club recognised or affiliated with Ski Racing Australia.
- **“Code of Conduct”** means the method by which all members of SRA, whether they be Competitors, Officials, Social Members or supporters, are required by the law to meet a minimum standard of conduct not only at sanctioned events but all social events whether held under the auspices of the SRA itself or a Constituent State Body.
- **“Competitors” or “Participants” or “Boat Crew” or “Team”** includes all persons competing and shall consist of “Driver and Observer” and “Skier and/or Skiers” being towed by the Boat.
- **“Incident”** is defined as any occurrence that results in a competitor needing to seek medical attention whether at the scene or following any competition.
- **“Incident Report”** is the written report that **MUST** be lodged advising that an “Incident” has occurred. The report **MUST** be lodged on the day the incident occurred and submitted to the SRA office within 7 days of the incident.
- **“Official”** means any person making decisions that could have an effect on the event including, judges, race organisers, any person/s responsible for setting the course, who may be called upon to give evidence in respect of any aspect of the sanctioned event.
- **“Race Day Report”** is located in the Boat Log Book and Race Day Book given to every boat owner. The Race Day Report **MUST** be completed and handed to race control at the end of each day’s racing or at the completion of each event, unless briefed otherwise. This Report is to include all falls irrespective of the need to seek medical assistance.
- **“Restricted Skier”** means any person who has not held a Skier’s membership during the last 5 years.

SKI RACING AUSTRALIA (SRA) RULE BOOK
SEASON 2011 – 2012

- **“Sanction” or “Sanctioned Event”** means an authorisation or approval of a certain event by the authorised body or organising committee, which binds the holders of the event to obey in full these Rules and Regulations, Conditions of Sanctioning or any other relevant policy and qualifies the results of events, if carried out in accordance with these rules for official recognition.
- **“Ski Racing Australia (SRA) Association Incorporated”** is the peak body responsible for the administration of water ski racing in Australia. Details of its roles and responsibilities are set out in its Constitution.
- **“Volunteer”** means any person who assists the organisers of the sanctioned event, who are instructed on what they are required to do and who do not have a direct input into the decision making process.

**SKI RACING AUSTRALIA (SRA) RULE BOOK
SEASON 2011 – 2012**

2. GENERAL

2.1. Guidelines and Application of the Rules. Includes references to the Code of Conduct, Drug Policy and Conditions of Sanctioning.

- (a) The Rules set forth are the Ski Racing Rules for sanctioned events by the Ski Racing Australia (SRA) the National Body. Whenever the masculine is used, the same shall be construed as meaning the feminine where the context so requires.
- (b) All competitors, crews, organising committees, officials, judges **MUST** have regard to the SRA Code of Conduct. The Code of Conduct is attached to this Rule Book at Annex A.
- (c) All Competitors, crews, organising committees, officials, and judges **MUST** have regard to the SRA Drug Policy. This Policy can be found on the SRA website, or a copy can be obtained from SRA's state representative, or from the SRA office.
- (d) Any Body seeking to host an SRA sanctioned event must do so in accordance with the Conditions of Sanctioning prepared by the SRA Board and as amended from time-to-time. Non-conformity with Conditions of Sanctioning may result in the loss of any future sanctioning.

2.2. Interpretation of the Rules

Question of interpretation of the rules shall be referred to the Ski Racing Director where possible, otherwise the interpretation shall be made by the Chief Judge. The Chief Judge shall make a report to the SRA Board concerning the question.

2.3. Application of Rules

These Rules are concerned with:-

- a) Circuit Races
- b) Distance Races
- c) Time Trials
- d) Marathons
- e) Lane Racing

2.4. Exception to the Rules

Where compliance with the rules is impossible, the Chief Judge shall, with the approval of a majority of the appointed Judges and Race Committee, make the necessary change,

**SKI RACING AUSTRALIA (SRA) RULE BOOK
SEASON 2011 – 2012**

inform each contestant and send a report to the State or Ski Racing Australia (SRA) Board, as applicable. Where the rules are definite and feasible, a vote of the Judges to decide whether to enforce any provision is prohibited.

2.5. Rule Book to be reissued at Beginning of each Season.

At the beginning of each season a new Rule Book will be issued incorporating any new rules and/or amendments that have been agreed by the SRA Board during the previous season. The Rule Book will be available to SRA members and will be found on the SRA website at www.skiracing.com.au. The rulebook shall be marked with the year and date of issue, and the version number

2.6. Amendments

- (a) These rules may be amended at any time by the SRA Board, but will not become effective until the beginning of each season (1 July). The only exception to this will be in the interests of safety. Rule amendments for safety reasons will become effective immediately upon notification to each State Secretary. An amendment page will be forwarded together with the reasons for the change.
- (b) Any amendment deemed necessary between meetings must be agreed to unanimously by each State, with final ratification by the SRA Board.

2.7. Non-Conformity with Rules

Sanctioned Events which are not organised in conformity with the Association's Race Rules may be declared "No Event" and the Body or organising committee disobeying or failing to carry out the rules herein, may be disbarred from conducting a Sanctioned Event for such period as shall be determined by the SRA Board.

2.8. Conducting an Sanctioned Event and Compliance with the Conditions of Sanctioning

- (a) The entire obligation of conducting a sanctioned event remains with the organising Body or Committee. The organising Body or Committee shall ensure that adequate Officials are in attendance for all requirements at an event.
- (b) The organising Body or Committee must be familiar with the Conditions of Sanctioning (as amended from time to time) and shall adhere to the conditions required to obtain sanctioning.
- (c) Failure of the organising Committee or Body to comply with the Conditions of Sanctioning may result in any future event being refused sanctioning.

**SKI RACING AUSTRALIA (SRA) RULE BOOK
SEASON 2011 – 2012**

2.9. Advertising of the Event

The Organising Committee conducting any Sanctioned Event/s should do all in their power to have the event/s advertised in the press and in any other way they deem fit to attract the public interest. The Organising Committee shall also provide reasonable facilities for the press on the day of the event/s and see that the results and description of the event/s are fairly and correctly recorded in the press.

2.10. Applicable Rules

These written rules governing the event together with any local government or authority's requirements should be made available to the owner or competitor of each boat entered for the event by the Body or organising committee conducting the event.

2.11. Schedule of Events

No later than one week before the start of the events, a Schedule of Events should be made available showing starting time for the competition. A schedule of starting times for individual events, if shown, shall be for the guidance of the contestants only, any deviation there from shall not constitute a change.

2.12. Calendar of Sanctioned Events

State SRA Committees shall, prior to the commencement of each racing season, prepare and forward a programme, for the endorsement of the SRA Board, detailing each States' proposed events including Australian and State Championships, together with the dates and venues.

2.13. Schedule Changes

- (a) Schedule event changes shall be made only for weather, water conditions, safety or similar reasons, and not for the convenience of any contestants. A majority of appointed Judges, or the Race Committee, must approve the change; all affected contestants must be notified.
- (b) On a notice of postponement, the Race Committee shall call a meeting of the contestants as soon as convenient. A new starting time and date, if the day is changed, will be set by the Race Committee and will be acceptable to the majority of competitors.

**SKI RACING AUSTRALIA (SRA) RULE BOOK
SEASON 2011 – 2012**

2.14. Sportsmanlike Manner

Competitors must act at all times in a sportsmanlike manner and in accordance with the SRA Code of Conduct, towards other competitors, officials, volunteers and spectators. Failure to do so may result in disciplinary action.

3. RESPONSIBILITY OF OFFICIALS & APPEAL PROCESSES

3.1. Chief Judge

- (a) A Chief Judge shall be appointed for all SRA sanctioned events.
- (b) The Chief Judge shall not serve as an Event Judge.
- (c) The Chief Judge shall supervise all judging and scoring operations and shall select the judges and assistants for each event.
- (d) A Jury shall be appointed by the Chief Judge to adjudicate on Rule infringements.
- (e) The Chief Judge shall appointment an Assistant Chief Judge.
- (f) The Chief Judge will be responsible for adequately appointing Judges, Timekeepers and Lap Scorers to cover the event. The Race Controller shall assist in the recruitment of these personnel if requested.
- (g) It shall be the responsibility of the Chief and Event Judges to attend the compulsory Briefing of Crews to assure themselves that all questions regarding the Rules and general conduct of the event etc. are thoroughly explained to all competitors.
- (h) The Chief Judge and/or the Race Controller is responsible for taking the necessary action against any competitor using unsafe equipment at any time (prior or during the event).
- (i) The Chief Judge shall be responsible for briefing all Judges prior to the event.
- (j) The Chief Judge has the authority to stop the race.
- (k) The Starter shall be a Judge or responsible person with experience of water ski racing. He/she will be appointed and briefed by the Chief Judge in consultation with the Race Controller.

**SKI RACING AUSTRALIA (SRA) RULE BOOK
SEASON 2011 – 2012**

3.2. Judges

- (a) All SRA Judges must have regard to the Code of Conduct (Annex A).
- (b) The control and observation at turn buoys shall be carried out by Judges or Lap Scorers, who will submit a report to the Chief Judge.
- (c) Judges shall be qualified Ski Racing Judges. They will be briefed by the Chief Judge and report infringements of the rules that they have observed to the Chief Judge as soon as possible. They are not empowered to impose any penalties directly. A register of qualified Ski Racing Judges shall be maintained by the SRA Judging Coordinator Board representative.
- (d) Boats, which can take aboard at least one Judge chosen by the Chief Judge, will stand at near proximity to all turns.
- (e) In mass start events there shall be a Judge in the start boat who shall be advised on the pole positions and shall ensure the line-up is correct. He/she may double as a turn judge once the race has started.
- (f) Only race officials and official Judges or Lap Scorers will be allowed on finish or turn boats, unless authorised by the Chief Judge.

3.3. Appointment of Jury for Disagreements

- (a) The Chief Judge shall appoint a Jury to hear disagreements. The Jury shall consist of a minimum of 4 Event Judges and a Chief Judge. In case of a disagreement between the Judges, the majority shall decide. In the case of a tie, the Chief Judge shall decide. The Chief Judge's decision shall be final for the event.
- (b) The Chief Technical Director shall appoint a technical jury to hear technical disagreements. The Jury shall consist of a minimum of 3 Scrutineers and a Chief Technical Director. In the case of a disagreement between the Scrutineers, the majority shall decide. In the case of a tie, the Chief Technical Director shall decide. The Chief Technical Director's decision shall be final for the event.

3.4. Grounds for an Appeal

- (a) The only grounds for an appeal are:
 - i. The procedure employed; or
 - ii. The severity of the penalty.
- (b) The Appeals Committee may only deal with any subsequent appeal against the procedure employed or the severity of the penalty incurred.

**SKI RACING AUSTRALIA (SRA) RULE BOOK
SEASON 2011 – 2012**

3.5. Appeals

- (a) The Appeals Committee to consist of: -
- Race Controller
 - Ski Racing Technical Director
 - Safety Officer
 - Chief Scrutineer
 - Judge (non Jury member)
- (b) i. The Chief Judge, or his or her nominated representative, shall be required to place evidence to the Appeals Committee as to the procedure employed and the penalty applied. An appeal must be lodged, in writing, with the Chief Judge, on the day within 30 minutes of the final official results being posted.
- ii. If the appeal is against a decision made by the Technical Jury the Chief Technical Director, or their nominated representative, shall be required to place evidence to the Appeals Committee as to the procedure employed or the penalty applied. An appeal must be lodged, in writing, with the Chief Judge, on the day within 30 minutes of the final official results being posted.

3.6. Official Timing

- (a) Official Timing method shall be at the discretion of the Chief Judge for the event, determined in conjunction with the Starter. Multiple timing, with Official Clocks, will be accurate to at least one hundredth of a second, this precision holding good as well for departure as for arrival of a skier.
- (b) Places in the competition shall be determined according to the skiing time made, after addition of the penalties if any.
- (c) No judge, jury or official shall have the power to award a time credit to any competitor, unless competitors are briefed accordingly.

3.7. Role of the Race Committee

- (a) State Race Committee/s shall be responsible for the management of State events, State Marathon and Speed Championship and the Australian Marathon and Speed Championship when hosted in the said State.
- (b) Region/Local Race Committee shall be responsible for the management of Sanctioned State and/or Region events when hosted in the said Region.

SKI RACING AUSTRALIA (SRA) RULE BOOK
SEASON 2011 – 2012

- (c) The Race Committee shall at least consist of the following Officials:
- i. Race Controller
 - ii. Ski Racing Technical Director
 - iii. Safety Officer
 - iv. Chief Scrutineer
- (d) In Events and Championships, the Race Committee will set the course, which shall meet with the Chief Judge's approval, alterations to the course must be made to the Chief Judge's approval, provided notice of such alterations is given to each competitor before the start of the event.
- (e) On a closed course, the Committee in control shall see that the course is clear of all traffic for a period covering the race (or heat) for five minutes before the start and five minutes after the completion of such event. The Championship course shall be laid down, ready for inspection, at least one hour prior to the Official starting time of the Championship for inspection and approval of the Chief Judge or his/her representative. This shall be extended to one day prior to the start of events for the Australian Speed and Marathon Championships.
- (f) The Body vested with the control of any Sanctioned Event shall see that the course and the competitors do not contravene any of the Regulations as laid down by any Government or Local Authority.
- (g) It is a minimum requirement of SRA that an on Duty Paramedic/Doctor must be in attendance at all SRA Sanctioned events. That person must have life saving medication and be qualified and approved to administer these medications. They must have the ability to contact local medical/rescue services. They must have appropriate current liability insurance cover.
- (h) It is desirable that the Organisers ensure adequate communications are maintained between all course Officials, course boats and the Chief Judge.

3.8. Duties and Responsibilities of the Race Committee

- (a) The Race Controller shall be the Chairman of the Race Committee and is responsible for overall management of the event.
- (b) The Ski Racing Technical Director is responsible for technical matters, which are the responsibility of the Race Committee and shall assist when necessary with interpretation of these rules.
- (c) The Safety Officer shall be a member of the Race Committee with expert knowledge of local water conditions. He/she shall be responsible for deployment of safety boats, liaising with coast guard and first aid services, and advising the Race Controller and Chief Judge of dangerous conditions. He/she may also be required

**SKI RACING AUSTRALIA (SRA) RULE BOOK
SEASON 2011 – 2012**

to advise the Race Controller on the likely safety of boats under local water conditions, before the Controller allows the first boat to start in a race. It is the Safety Officer's responsibility to check that all competing and official boats are safely accounted for at the conclusion of racing.

- (d) Rescue boat drivers will be briefed by and responsible to the Safety Officer.
- (e) All judging and rescue boats should carry appropriate fire-fighting equipment.
- (f) The Safety Officer shall remain in contact with the Chief Judge during the race. It is strongly recommended that intercommunicating radios be used.
- (g) The Chief Scrutineer shall be appointed by reason of his/her special technical knowledge of ski boats and their use in water similar to that on which the race will take place. He/she is responsible for seeing that no boat starts in the race until a visual technical scrutineering has been carried out and that the engine/s fall within the class structure for which entry has been made.
- (h) The Chief Scrutineer will be responsible to the Race Controller and Ski Racing Technical Director, and the scrutineering standards which should be aimed at are in accordance with rules contained within this book.

3.9. Conflict of Interest

- (a) Should any Official/s find themselves in a position that could be deemed to be, or the potential for, a conflict of interest, they are to advise the organising body accordingly as soon as they become aware.
- (b) If this matter cannot be resolved by the organising body, then this should be referred to the SRA board for resolution.

3.10. Race Day Report

The Race Day Report **MUST** be completed and handed to race control at the end of each day's racing or at the completion of each event, unless briefed otherwise. This Report is to include all falls irrespective of the need to seek medical assistance.

3.11. Boat Log Book & Race Day Book

- (a) Boat Log Book & Race Day Book shall be issued to each boat owner for every competing boat. This book must be presented at all scrutineering and at all other times where scrutineering is required prior to an event. Failure to present the book for scrutineering will result in the boat not being allowed to compete.

**SKI RACING AUSTRALIA (SRA) RULE BOOK
SEASON 2011 – 2012**

- (b) Boat Log Book & Race Day Book must be presented to the Chief Judge upon request. Failure to present the book to the Chief Judge upon request will result in disqualification or cancellation of future entries.
- (c) This book must be kept with the boat at all times and made available for the inspection by SRA officials when required/requested to do so.
- (d) Lost books must be notified immediately to SRA who may request written details to be supplied prior to the issuing of a new book.
- (e) A hard copy of the current rulebook with the boat's name on it must be carried and be presented with the Boat's logbook upon request. An Electronic version of the rule book is acceptable.

3.12. Fuel (refer 9.14 Fuels)

No refuelling allowed in the water at any SRA sanctioned event.

3.13. Incident Report Form to be completed

- (a) Should an incident occur, it is the responsibility of one of the event organisers or the Chief Judge to arrange for either the competitor and/or a crewmember to complete an Incident Report Form and return it to SRA Canberra within seven (7) days following the Incident. Copies of ALL reports obtained regarding the incident are to be obtained, copied and returned to SRA Canberra. Incident Report Forms are available from each State Secretary or the SRA office.
- (b) Should the injury to the competitor not be apparent during the event, but becomes known following the event, then it is the responsibility of the competitor and/or the crew to advise the Chief Judge or the Organisers immediately they become aware of the incident. The Chief Judge or the event Organisers will arrange for an Incident Report Form to be forwarded to the crewmember who will complete the form and return it to SRA in Canberra within seven (7) days. A copy of the Incident Report Form is to be forwarded to either the Chief Judge or the event Organisers who will retain it for their records.

4. SCORING OF EVENTS AND POINTS AWARD

4.1. Scoring

- (a) Method of Scoring will be determined by the type of event. The Ski Racing Committee will advise the contestants prior to the event as to how the winner and, if

**SKI RACING AUSTRALIA (SRA) RULE BOOK
SEASON 2011 – 2012**

any, placegetters will be determined, viz. fastest time, shortest elapsed or corrected time, etc. In general the skier will be judged unless otherwise stated.

- (b) Scoring of the event by the Judges shall be made available for inspection as soon as possible after each event, but not later than the end of the day's events.
- (c) The results of each sanctioned event, along with two sets of score sheets for that event, will be neatly and accurately presented to the Points Recorder no more than seven working days following that event.
- (d) Tied Scores: In the event of tied scores, contestants involved may share equally any trophies.
- (e) A race may be declared official if the lead boat has completed at least 50% or more of the race in question, according to the official score sheets.
- (f) A time penalty of one minute may be imposed for minor rule infringements.

4.2. Point Scoring

- (a) Suggested Point Scoring System for Sanctioned Ski Racing Events and SRA Series
The Series is run on a point score basis with the first six placed teams in each class in each race receiving the following points:

20 first, 14 second, 10 third, 8 fourth, 6 fifth,
4 sixth, 2 points for a start and a finish and
1 point for a start and a non-finish
- (b) Substitutions: The substitution is applicable to boats, drivers, observers and skier/s. The Team will not qualify for substitution if less than 3/5ths of the Team (including boat) are consistent in each event.
- (c) Point scoring to be taken on 51% (or nearest above) of all point scoring events.

5. INFRINGEMENTS & PROTESTS

5.1. Protests

- (a) Protests shall be made to the Chief Judge by the team representative. Protests must be made in writing, giving the reasons for the protest and be filed within 30 minutes after the provisional results of the event are announced or posted.

**SKI RACING AUSTRALIA (SRA) RULE BOOK
SEASON 2011 – 2012**

- (b) Protests directed against another contestant shall be made to the Chief Judge by the team representative. Protests must be in writing and indicate the reason for the protest. Protests must also give the names or identity of any other witnesses. They must be filed within 30 minutes after the arrival of the participant.
- (c) Protests must be accompanied by a fee of \$100.00. This amount will be refunded if the protest is considered reasonable by the Judges.

5.2. Resolution of Protest

- (a) The Chief Judge shall form a Jury to resolve any protest if required.
- (b) The Jury shall not overrule any judgement a Judge has made during the running of an event.
- (c) A decision shall be made after a meeting with only the participants concerned, away from any crowd, and after a vote has been taken in private.

5.3. Notification of Results

No results shall be posted whilst a Protest is pending.

5.4. Error in Results

- (a) A correction of an error in the computation of scores shall not be considered a protest and the correction shall be made upon approval of the Chief Judge if requested. Results shall be final for all events within one hour after the results of the event are announced and the judges scoring forms are available for inspection.
- (b) Only OFFICIAL TIMES by Judges, Official Time-keepers and official Scorers will be recognised.
- (c) No PROTEST shall be permitted on judgement decisions by the Judges.

5.5. Disqualifications and Penalties

- (a) Disqualifications may be imposed for any of the following or similar items:-
 - i. Where any boat or skier, in the opinion of the Chief Judge, is proved to be behaving in a dangerous manner or contrary to the Governing Body rules.
 - ii. Any boat or driver demonstrating poor handling ability or creating a safety hazard.

**SKI RACING AUSTRALIA (SRA) RULE BOOK
SEASON 2011 – 2012**

- iii. Anyone running so close to the course during a race so as to interfere with the event.
 - iv. Any blocking or turning wide.
 - v. In the opinion of the Judges, any participant exhibiting unsportsmanlike conduct during the running of the events.
 - vi. The violation of running on a course that is closed will subject the boat and driver to a penalty for the first infringement and disqualification from that meeting for subsequent infringements.
 - vii. Refusing to give way to other competitors whilst on course.
 - viii. Should a boat or its competitor commit a breach of these rules which is of a minor nature and in the judgement of the Judges has no direct effect on the relative positions of the boats at the finish, the Chief Judge or their appointee shall have the power to decide whether or not a boat or competitor shall be disqualified or a lesser penalty may be imposed. A time penalty of one minute may be imposed for minor rule infringements for which no other penalty is prescribed.
 - ix. Penalties will be imposed for rule infringements by the Chief Judge or their appointee. Competitors have the right to appeal.
 - x. The boat crew must be advised of infringements or penalty by the Chief Judge prior to announcement of results.
 - xi. No abuse or offensive language to Judges or Officials will be permitted.
 - xii. Any accident involving property damage or personal injury must be reported on the day to the Chief Judge of the event. Failure to do so could result in non-acceptance in future events for all crew members involved.
 - xiii. For contravention of Circuit Racing Rule 16 excluding 16.2, 16.12, 11.23, 11.24(a), the Chief Judge will impose penalties upon a team by adding a time of up to 10% of the time of the first skier crossing the finish line, for each offence to that of the defaulting team. For contravention of the Mass Start Procedure the penalty will be one minute added to the competitors time.
 - xiv. In a race where the chequered flag is not being used to denote the finish of the race, any boat completing more than the prescribed number of laps shall be disqualified.
 - xv. A team shall not be disqualified if wrongly compelled to do so by another boat, or where the jury is satisfied that a rule has been breached for safety reasons ONLY, and that the team breaching the rule gained no advantage.
- (b) For contravention of 16.2, 16.12 (re acknowledging fallen skier), 11.20(c), 11.20(e) (re safety flag to remain visible), 11.20(f), 11.22(b), 11.22(c), 11.22(d) the Chief Judge will impose a penalty of one minute added to the competitor's time.

5.6. Disqualification

- (a) A driver receiving two disqualifications for violations during a single sanctioned event may be disqualified for the rest of that day's events. Any driver disqualified

**SKI RACING AUSTRALIA (SRA) RULE BOOK
SEASON 2011 – 2012**

for violations four times during a calendar year may be disqualified for the remainder of the sanctioned races that ski racing year

- (b) Penalties for moving violations will apply to an entire team (skier, driver and observer).
- (c) The Race Controller must be notified of any disqualifications.

5.7. *Serious Contravention of the Rules*

- (a) For a serious contravention of the rules, the Chief Judge may, with a majority decision of his Committee, disqualify and/or recommend the suspension or removal of a ski racing driver's licence to the Race Committee. The re-issue of this licence, however, will be done through the offender's State Technical Committee on re-application by the driver.

5.8. *Summary Judgement*

The Chief Judge and his/her Committee shall have the right to give summary judgement on any happening unforeseen in these rules.

5.9. *Exclusions from Events*

- (a) If in the opinion of the Judges or Race Committee, the conduct of a participant/s is against the best interest of the Association or Body, the Race Committee may exclude such member/s from participating in events under its control.
- (b) Boats that constitute a danger or non-bonafide entries, shall not be permitted to race. The Judge's and Race Committee's decision is final.
- (c) Any boat or participant failing to comply with one or more of the rules contained within Sections 6, 7 and 8 of these rules, and in the opinion of the Race Committee should not enter an event as a result of non-compliance.

6. COMPETITION REQUIREMENTS

6.1. *Drugs and Alcohol*

- (a) A competitor who is under the influence of a non-prescribed drug, restricted prescribed drug, cannabis, narcotics and stimulants (such as amphetamines, cocaine, etc), shall be liable to immediate suspension from competing in events on that day and shall be liable to disqualification from events already competed in on that day.

**SKI RACING AUSTRALIA (SRA) RULE BOOK
SEASON 2011 – 2012**

- (b) A competitor who is found to have used a non-prescribed drug or restricted prescribed drug contrary to the SRA drug policy shall be liable to disqualification and such other penalty as prescribed by such policy.
- (c) Subject to Rule 6.1(j), a competitor shall not consume any alcohol on the day of an event. A competitor, who has consumed alcohol, on the day of the event, shall be immediately suspended from competing in all events on that day.
- (d) A Competitor who is under the influence of alcohol shall be liable to immediate suspension from competing in events and shall be liable to disqualification from events already competed in on that day.
- (e) It shall be absolute proof of a Competitor “being under the influence” if there is present in that competitor’s blood a concentration of alcohol of in excess of 0.00 grams in 100 millilitres of the blood, or such lower concentration as may be prescribed by any relevant state laws.
- (f) The Race Committee or the Chief Judge, or anyone authorised by the Race Committee or the Chief Judge, shall have the power to require any Competitor at any time during the running of events or prior to the running of events on any day to submit to a breath test or breath analysis for the purposes of ascertaining the concentration of alcohol in that person’s blood by use of a breath testing or breath analysis device approved of for that purpose.
- (g) Breath testing must be completed 15 minutes prior to the advertised start time of the event. Nothing contained in this rule shall prohibit the Chief Judge from conducting a random breath test.
- (h) No minor can be breath tested without the consent of his/her parent or guardian or crewmember or without the approval and in the presence of the Chief Judge or his/her nominee.
- (i) Any Competitor refusing to undertake an authorised breath test or breath analysis shall be liable to immediate suspension from all events on that day and shall be liable to disqualification from all events competed in on that day.
- (j) Nothing contained herein shall apply to alcohol consumed after the completion of that Competitor’s competition in events on that day, that is after a competitor reaches the bank following the completion of his/her final event of the day.
- (k)
 - i. Any competitor asked to undertake a breath test must record a blood alcohol level of 0.00.
 - ii. If that competitor is over they may be able to retest to within 15 minutes of the advertised start time of the event.

**SKI RACING AUSTRALIA (SRA) RULE BOOK
SEASON 2011 – 2012**

iii. If that competitor is still over 0.00 at this time the competitor will be disqualified from that event.

(l) A reference herein to a “Competitor” shall also include reference to an “Official” or other participant in an event.

6.2. Competition Divisions, Age of Competitors, Maximum Boat Litres & Social Class Rules

(a) Competition in each event may be separated into the following sections:-

i. Divisions NB: male and female (including boys & girls) are to be separate divisions

ii. Divisions	
Under 10 Years	Tiny Tots Boys and Girls
10 - Under 13 Years	Sub-Junior Boys and Girls
13 - Under 16 Years	Junior Boys and Girls
16 - Under 19 Years	Boys and Girls
19 - Under 25	Men and Women (Speed Events Only)
25 - Under 30	Men and Women (Speed Events Only)
30 - Under 40	Men and Women (2nd Division)
40 - Under 50	Men and Women
Over 50	Men and Women
Open - No age limit	Men and Women
Social - Men/Women	No age limit
Novice Men/Women	Any Age (NOT IN NATIONAL EVENTS)

iii. Ages and dates specified in (a) above shall be for the Ski Racing Calendar Year.

iv. Ages of competitors prior to midnight on the 30th June of the current Ski Racing Calendar Year, determines the age Divisions for the following season.

v. All boat motor capacity for Divisions are unrestricted - total displacement of the engine(s) should not exceed 9.42 litres.

(b) In 2 Up Events (where two skiers are skiing behind a boat e.g. Super Series, NSW/ACT Championship Series):-

i. Skiers may ski in any engine class;

ii. In age classes, skiers must enter their age class;

iii. Mixed aged entries will be permissible. e.g. a 13- Under 16 Boy may ski in the 16 – Under 19 Boys class with a 16 – Under 19 Boy.

a) A skier may ski in any age division as a member of a mixed aged entry;

**SKI RACING AUSTRALIA (SRA) RULE BOOK
SEASON 2011 – 2012**

- b) Mixed aged skiers may enter together behind a boat. However, one of the two skiers entered behind the boat must qualify for the age division entered. The age of the eldest skier will determine the class entered.
- c) Mixed sex entries are permissible. Class to be determined by the elder skier unless contrary to Rule 6.13.1 e.g. 13 – Under 16 Boy skiing with a 16 – Under 19 Girl would qualify for 16 – Under 19 Boys as Rule 6.13.1 stipulates 13 – Under 16 Boy would go up to 16 – Under 19 Boys.

6.3. Novice Classes

- (a) *First Year novice* - is open to skiers in their first season of racing having never competed in any sanctioned event. A skier can only ski in First Year novice for one season.
- (b) *Novice & Social Novice* - can only compete in this class for a maximum of 2 seasons.

6.4. Social Class

The spirit of the rules of Social Class is to provide a class in which the majority of social skiers may be competitive (depending on their skiing skill) without necessarily spending money on special skis. The skis used should not have a significant advantage over any of the commonly available and popular slalom skis.

6.5. Social Class Ropes

Maximum allowable length is 36 metres (118 ft) from the transom of the boat to the handles.

6.6. Social Class Skis

- (a) The front foot binding is unrestricted, i.e. any social or racing binding can be used.
- (b) Social class skis:
 - i. The rear foot binding is restricted to a toe piece only. No heelpiece may be used, i.e.: no part of the fitting may support the heel or the ankle. If a heelpiece or ankle strap is standard, these pieces must be removed from the ski to be eligible. A sole plate may be used with a maximum 2mm base plate and a continuous from front to rear rubber strip with a maximum 3mm thickness. No wedge may be used under the foot, no toe grips or supports, no indentation in the top surface of the ski. Roughened surfaces are

**SKI RACING AUSTRALIA (SRA) RULE BOOK
SEASON 2011 – 2012**

allowable under the rear foot with equal density must be continuous from in front of the rear toe to behind the rear heel; contact roughened sole pieces may be used, provided the total thickness of any or all sole pieces is no more than 5mm thick, above the top surface of the ski. No other form of support or adhesion for the rear foot is allowed either outside, under or within the rear foot binding. Competitors are permitted to tape ski bindings as long as it is in accordance with Rule 8.19.

- ii. The maximum thickness for the ski is 2.2 cm.
- iii. The ski must have a concave bottom surface. This concave must be at least 0.5 cm deep and 7.0 cm wide, and being of a curve and blended cross-section. This section should start in front of the front foot piece and extend rearwards to behind the back of the rear foot piece, this section being at least 70 cm.
- iv. The ski must fit in a box of the following internal dimensions:
 - a) Length: 175 cm
 - b) Width for front 100 cm of box: 20 cm
 - c) Width at back edge of box: 7.5 cm
 - d) The box will taper uniformly and symmetrically from 20cm to 7.5cm over the last 75 cm of its length.
 - e) The front edge of the box will be 18 cm high so that the tip of the ski will not pass over it.
 - f) There will be a space cut in the bottom of the rear of the box, large enough to allow any fins to pass through.
 - g) The ski must be placed flat on the bottom of the box with the rear of the ski against the rear of the box, and the centre line of the ski along the centre line of the box.
- (c) Virtually all-common skis will fit into the box. Due to manufacturing tolerances some of the popular social skis do not always fit. Skis which comply to the spirit of the rules will be allowed, i.e. those which in the opinion of the race day committee do not give a significant advantage. Square back skis such as wake jumpers, do not fall within the spirit of the rules and will not be allowed unless modified to fit into the box. Specially made skis designed to take full advantage of the rules will be allowed only if they meet all the requirements, i.e. they must fit into the box.
- (d) Social Class skis shall be slalom type skis. No racing skis permitted.

6.7. Outboard Classes

Outboard

- i. **200HP Outboard. Standard production motor with maximum manufacturer/official rating of 200 Horse Power. Standard Outboard definition applies, refer section 9.9.**
- ii. Formula 2 as per World Rules.

**SKI RACING AUSTRALIA (SRA) RULE BOOK
SEASON 2011 – 2012**

- iii. SMOC (Standard Motor Open Cockpit). Up to 250 Advertised Horse Power Standard Production Motor. Standard Outboard definition applies, refer section 9.9. Open Cockpit Hull definition applies, refer section 9.10.
- iv. MOC (Modified Open Cockpit). Modified Production Motor, refer section 9.8. Open Cockpit Hull definition applies, refer section 9.10.
- v. Unlimited - Twin Rigs, Modified or Super Sports - Total displacement of the engine(s) should not exceed 9.42 litres.

6.8. Inboard Classes

Inboard

- i. Stock 6 litre.
- ii. Under 5.2 Litre
- iii. Under 6.0 Litre
- iv. Under 8.0 Litre
- v. Forced aspirated or turbo charged and 2 stroke motors in above to receive a 1.7 penalty. The base capacity is to be multiplied by a factor of 1.7 to assess actual capacity.
- vi. Unlimited - Modified, Unrestricted and Multiple Engines - Total displacement of the engine(s) should not exceed 9.42 litres.

6.9. Super Class

Super Class - Special Class at the discretion of the SRA Board.

6.10. 60 mph Class

- (a) Competitors must not exceed 60mph. Competitors must purchase an EDGE 205 or 305 GPS from SRA. This GPS tracks speed, distance and maps the course which will be downloaded to a SRA computer for analyses at the end of the event. Only SRA approved GPS speed-readings will be recognised.
- (b) It will be the responsibility of the crew to fit the GPS in a position where it is going to track correctly. The crew will present their GPS to the officials before racing fully charged and cleared of all history ready to use. Only GPSs checked and cleared before racing will be accepted for downloading.
- (c) It will be the responsibility of the crew to start the GPS timer before leaving the bank and stop the GPS timer after the race is completed. Where there are two legs to a race it will be the responsibility of the crew to stop and restart the GPS on the second leg. All speed restricted competitors must present their GPS to be downloaded regardless if they finish or not within 30 mins of completion of their race. For those broken down, downloading of GPS to be as soon as practical.

**SKI RACING AUSTRALIA (SRA) RULE BOOK
SEASON 2011 – 2012**

- (d) Any competitors GPS registered with SRA that do not give readings **with a complete map/track** upon return will **be disqualified**.
- (e)
 - i No GPS activated speed control is to be used.
 - ii Appeals or protests will not be permitted on GPS readings.
 - iii No systems allowed to over ride driver throttle control, throttle stops must not be able to be adjusted whilst underway.
 - iv The driver is the only person to have any physical control over the throttle.
 - v The driver is the only crewmember to be able to read any GPS in the boat. The observer must keep their full attention on the skier/skiers.
- (f) All boats must meet the requirements of the 60mph scrutineering safety sheet.
- (g) **Skies and rope lengths are unrestricted, except for social.**
- (h) In any event entered, all boats must tow at least 1 restricted membership skier. Restricted skier is defined as: *Any person who has not held a full skier's membership during the last 5 years.* But in exceptional circumstances an application may be made to the SRA Board for exemption.
- (i) Restricted skiers may ski in 60mph and Marathon classes.
- (j) Any boat driver found to be exceeding 65mph twice or 70mph once in one season shall no longer be eligible to compete in 60mph class for a period of 12 calendar months.
- (k) Any Garman edge 205/305 GPS purchased outside of SRA may be sent to SRA for registration and upgrading to be allowed to be used in 60/70mph classes. This will incur a \$50 fee.
- (l) Driver and Observers must have had a medical, undertaken in accordance with SRA requirements and hold a current drivers or observers licence. Bright orange helmets must be worn. Life jackets must have leg straps and be brightly coloured (brightly coloured T-shirt may be worn over the jacket). Jackets must be in good condition with no rips, tears or missing straps. Footwear with enclosed toes to be worn whilst racing. Drivers suits are required refer to rule 8.8(b).
- (m) Skiers must wear fluorescent orange helmets. Life jacket (with leg straps) or wet suit with suitable buoyancy must be worn. The wet suit or life jacket must be brightly coloured (brightly coloured T-shirt may be worn over the wet suit or life jacket). All jackets or wet suits must be in good condition with no rips, tears or missing straps.
- (n) Teleflex steering: up to 175 HP single system may be fitted, over 175 HP dual system must be fitted.

**SKI RACING AUSTRALIA (SRA) RULE BOOK
SEASON 2011 – 2012**

6.11.70 mph Class

- (a) Competitors must not exceed 70mph. Competitors must purchase an EDGE 205 or 305 GPS from SRA. This GPS tracks speed, distance and maps the course which will be downloaded to a SRA computer for analyses at the end of the event. Only SRA approved GPS speed-readings will be recognised.
- (b) It will be the responsibility of the crew to fit the GPS in a position where it is going to track correctly. The crew will present their GPS to the officials before racing fully charged and cleared of all history ready to use. Only GPSs checked and cleared before racing will be accepted for downloading.
- (c) It will be the responsibility of the crew to start the GPS timer before leaving the bank and stop the GPS timer after the race is completed. Where there are two legs to a race it will be the responsibility of the crew to stop and restart the GPS on the second leg. All speed restricted competitors must present their GPS to be downloaded regardless if they finish or not within 30 mins of completion of their race. For those broken down, downloading of GPS to be as soon as practical.
- (d) Any competitors GPS registered with SRA that do not give readings **with a complete map/track** upon return will **be disqualified**.
- (e)
 - i. No GPS activated speed control is to be used.
 - ii. Appeals or protests will not be permitted on GPS readings.
 - iii. No systems allowed to over ride driver throttle control, throttle stops must not be able to be adjusted whilst underway.
 - iv. The driver is the only person to have any physical control over the throttle.
 - v. The driver is the only crewmember to be able to read any GPS in the boat. The observer must keep their full attention on the skier/skiers.
- (f) All boats must meet full SRA safety scrutineering.
- (g) Skies and rope lengths are unrestricted, except for social.
- (h) In any event entered, all boats must tow at least 1 restricted membership skier. Restricted skier is defined as: *Any person who has not held a full skier's membership during the last 5 years*. But in exceptional circumstances an application may be made to the SRA Board for exemption.
- (i) Restricted skiers may ski in 70mph and Marathon classes.
- (j) Any boat driver found to be exceeding 75mph twice or 80mph once in one season shall no longer be eligible to compete in 70mph class for a period of 12 calendar months.

**SKI RACING AUSTRALIA (SRA) RULE BOOK
SEASON 2011 – 2012**

- (k) Any Garman edge 205/305 GPS purchased outside of SRA may be sent to SRA for registration and upgrading to be allowed to be used in 60/70mph classes. This will incur a \$50 fee.

6.12. Substitutions

- (a) Substitution of a boat and/or skier in the same class or division shall be permitted 30 minutes, or less at the Judges' discretion, prior to the start of an event. The withdrawn boat and/or skier shall be eligible to re-enter other events on the day. The withdrawn boat and/or skier must be proven to be unable to compete.
- (b) Qualifying Substitution - May substitute boats or skiers in engine class or age division events. A boat must be nominated initially, the initial boat must be proved to be mechanically unsound.
- (c) If there is to be a change in any boat or crewmember, the Team Captain must advise the appropriate race organiser in writing prior to the event. Failure to do so results in disqualification from that event.
- (d) Only one boat may be used to pull a skier/skiers in any one event. Two heats constitute one event. If a skier has qualified for the main event but finds his boat becomes disabled between his qualifying heat and the final race, the skier may enter a second boat.

6.13. Guidelines for Events other than Australian Speed and Marathon Championships

- (a) Where there are less than two contestants entered in a scheduled event, the event in the division or class shall not be held and the contestants may then compete in the next division or class above, as follows:-
- | | | |
|-------|---------------------------------------|--|
| i. | Inboards to next highest litre class, | 6 cylinder to corresponding litre class |
| ii. | Outboards to next highest litre class | |
| iii. | Under 10 Tiny Tot Boys | to 10 - Under 13 Boys or 13 - Under 16 Girls |
| iv. | Under 10 Tiny Tot Girls | to Under 10 Tiny Tot Boys or 10 - Under 13 Girls |
| v. | 10 - Under 13 Boys | to 13 - Under 16 Boys |
| vi. | 10 - Under 13 Girls | to 13 - Under 16 Girls |
| vii. | 13 - Under 16 Boy | to 16 - Under 19 Boys |
| viii. | 13 - Under 16 Girl | to 16 - Under 19 Girls |
| ix. | 16 - Under 19 Boy | to 19 - Under 25 Men |
| x. | 16 - Under 19 Girls | to 19 - Under 25 Women |
| xi. | 19 - Under 25 Men | to Open Men |
| xii. | 19 - Under 25 Women | to Open Women |

**SKI RACING AUSTRALIA (SRA) RULE BOOK
SEASON 2011 – 2012**

xiii.	25 - Under 30 Men	to	Open Men
xiv.	25 - Under 30 Women	to	Open Women
xv.	30 - Under 40 Men	to	Under 30 Men (Speed events only) or to Men
xvi.	30 - Under 40 Women	to	Under 30 Women (Speed events only) or to Women
xvii.	40 - Under 50 Men	to	30 - Under 40 Men
xviii.	40 - Under 50 Women	to	30 - Under 40 Women
xix.	Over 50 Men	to	40 – Under 50 Men
xx.	Over 50 Women	to	40 – Under 50 Women
xxi.	Social Men and Women	to	relevant age

6.14. Definition of Novice Skier

- (a) To qualify as a novice class skier, in any of the divisions, the skier shall never have skied in an age division at any event sanctioned by SRA. **With the exception of 60/70mph.**
- (b) Novice skiers may compete in two-up events in an engine or age division. Once a skier has trophied three times in any two-up events they will be automatically excluded from competing in novice events. (Trophied shall mean finishing in first place.) (Excludes 60/70 mph.)
- (c) Novice skiers can compete behind any boat.
- (d) Novice skiers can only compete in novice classes for a maximum of 3 seasons.
- (e) All novice competitors must complete a novice application form listing all previous experience at any sanctioned event whether one-up or two-up prior to entering in any of the novice classes. This application is to be sent to their state body that will certify the information and forward the application to SRA. Novice status will be indicated on SRA membership card.
- (f) Novice Class is not applicable to Australian Speed and Marathon Championships.

6.15. Crew to Wear Full Race Gear

Any time a boat is under power or testing, outside the pit area on race day, all occupants are required to wear full race gear. When a boat is on the plane idling back upon completion of an event no race gear is required to be worn.

**SKI RACING AUSTRALIA (SRA) RULE BOOK
SEASON 2011 – 2012**

7. GENERAL BOAT REQUIREMENTS AND SAFETY

7.1. Boat Safety Inspection

- (a) Dry land boat safety inspection - prior to or during entry hours, boat requirements and safety inspection may be effected.
- (b) A Scrutineering Certificate of Safety Compliance will be issued to each boat each calendar year, but this Certificate may be revoked should compliance with safety regulations not be maintained upon the boat at any time during the season.
- (c) Failure to present the logbook for scrutineering will result in the boat not being allowed to compete.
- (d) At the SRA pre season safety scrutineering, boat to be presented with top line shaft cover unassembled for inspection.

7.2. Boat & Equipment Inspection Prior to or During an Event

- (a) Boat and equipment shall be available for examination at least one hour prior to the start of the event and may be inspected by an SRA Official and if found not to be in compliance with governing rules or regulations, the Committee may refuse to allow the boat to start. Corrections or substitution may be permitted if made prior to competing in the event, but the start shall not be delayed to allow compliance.
- (b) Boats involved in any serious incident must be presented to officials before continuing racing.

7.3. Non-Compliance with the Rules

The owner or his/her representative must be notified immediately by the SRA officials prior to the start of the event, if it is found on inspection that any rules have not been complied with and the owner or his representative shall be granted the privilege of complying with the rules prior to the start of the event. If the rules are not then complied with, officials may decline to permit the boat to start.

7.4. Vessels to be registered

All boats must be currently registered with the controlling State Maritime Authority.

**SKI RACING AUSTRALIA (SRA) RULE BOOK
SEASON 2011 – 2012**

7.5. Compliance with Authority Requirements and/or Regulations

All boats are to comply with any requirements or regulations stipulated by the Authority, unless an exemption has been obtained by the Organisers of the event.

7.6. Vessel to be registered with SRA

Each boat must be registered with the Ski Racing Australia in accordance with the requirements from time to time. (Boat Registration with SRA includes Public Liability Insurance Cover). On the request of an official, the driver of the boat must produce his current Boat Membership Card and any vessel renewal details should the vessel be unregistered at that time.

7.7. Vessel Structural State

Scrutineers are not expected to undertake a “condition survey” of the boat, but general appraisal shall be made of the structure. The following should be checked.

- i. Split planks, fractured frames and beams and transom knees or their equivalent in reinforced plastic or alloy hulls.
- ii. Steering mounting (structure).
- iii. Shaft brackets and mechanical items other than those already covered.
- iv. Bilge should be free of oil or debris. Remember oil causes structural deterioration, fuel is dangerous and debris chokes pumps etc.

7.8. Vessel Design

The design of a boat or a combination of hull and power source, must be compatible for speeds travelled during events. The owner must provide proof of safety of boat handling if requested.

7.9. Restrictions to Boat Names & Associated Materials

- (a) Restrictions shall apply to the name of a boat. No name, mural or advertisement shall be permitted that is obscene, in breach of good taste or of such a nature as to cause embarrassment or to bring the sport of water-skiing into disrepute. This shall apply to double meanings, innuendoes or in a language other than English.
- (b) All of the restrictions listed in Rule 7.09(a) shall apply to the team/crew members' clothing and apparel, tow vehicles, trailers and any equipment, or any object brought to the venue by the competing team/crew.
- (c) Should a dispute arise regarding this rule, the final determination and applicability shall rest with the SRA Board.

**SKI RACING AUSTRALIA (SRA) RULE BOOK
SEASON 2011 – 2012**

7.10. Towing Cleat or Eye, or Sampson Post

- (a) Shall be adequate in itself and shall be adequate for towing the boat when water logged.
- (b) Shall be strongly fixed to the structure, not merely to the decking. It should be remembered that this item may have to carry the whole weight of a waterlogged boat.

7.11. Painter/Tow Lines (if fitted)

- (a) Shall be strong enough for the purpose.
- (b) Tow lines 4 meters long 10mm thick with a snap hook diameter of hook 8mm one end and loop on the other end. Tow line must be carried in the boat.
- (c) Painter Line shall not be long enough to reach the propeller. When requested the painter line shall be attached to a bow eye and shall be secured in the cockpit.

7.12. Sharp Edges

- (a) All mascots, lights, bow fittings and other sharp edges shall be adequately protected or removed.
- (b) Fixed aerofoils or adjustable aero trimming devices attached to the hull or engine must be securely fixed and stayed.

7.13. Windshield

- (a) Shall be well secured.
- (b) Shall not be of plate or ordinary glass.
- (c) Scrutineers may order the removal of any windshield that appears dangerous.

7.14. Steering Gear

- (a) Steering wheel and drum shall be secured and locked on to the shaft.
- (b) Steering wheel unit shall be fixed to, or through, the dash panel or a steering mounting bar and shall be through bolted and locked.

**SKI RACING AUSTRALIA (SRA) RULE BOOK
SEASON 2011 – 2012**

- (c) Steering wheel strength shall be checked, if the wheel is split or cracked the wheel shall be rejected. Wheels of the laminated rim type shall be checked for wear caused by the breakdown of the laminations. Plastic composition wheels shall be checked for early fatigue where the spokes join the boss to ensure the wheel cannot be forced to spin on the internal boss without undue minimum amount of pressure.
- (d) Where shackles or such devices are used to attach the steering to outboard engines, they shall not be of a non-ferrous metal. Scrutineers shall satisfy themselves that this is so even if the shackles are painted.
- (e) Pulleys shall operate freely and shall be through bolted with positive locking at the swivel connection. Steering pulleys and pins/rollers or shackles with any visible wear must be replaced.
- (f) Steering wires shall be in good condition and shall have free running throughout their path, with adequate tension throughout their travel.

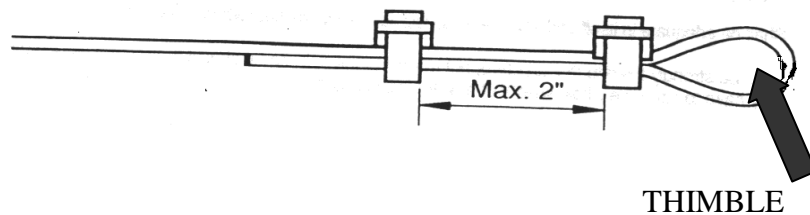

- (g) Wires shall be secured and where doubled to form an eye shall be around the thimble to protect the wire from wear or folding and then be secured with cable grips or equivalent as per diagram. Minimum diameter used will be 4mm diameter 7 ply x 19-strand stainless steel, steel or galvanised steel as per diagram below. Clamps must be fitted with the largest holding area of the clamp on the load carrying length of cable and the smallest holding area of the clamp on the tail end of the cable. All clamps must face the same direction and must not be altered. Minimum of two (2) clamps, to be fitted on each ending.

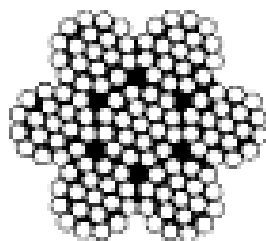

- (h) There shall be no undue degree of play in the steering system, but steering wires shall not be over-tightened in a “piano-wire” fashion.
- (i) For outboards — attachments to the engine, for inboards attachments to tillers and/or quadrants and their fitting to the stock shall be in good condition and secure.

**SKI RACING AUSTRALIA (SRA) RULE BOOK
SEASON 2011 – 2012**

- (j) Engine or tiller and rudder shall operate with full and free movements in the correct sense and shall be fitted with stops to prevent over-control.
- (k) Rudder assemblies, gland keys etc. shall be in good condition and secure with locked nuts and/or tight split pins.
- (l) For rod steering, the rods are to be sufficiently rigid to prevent undue flexing.
- (m) Rack and pinion steering shall be in good mechanical condition with no excessive backlash. Casings should also be checked.
- (n) All pulleys with riveted swivel attachments, are not to be used on any boat, pins of non-ferrous materials shall be rejected or the pins shall be replaced by a positively locked steel/stainless steel bolts. Pulleys should also, if possible, incorporate a bush.
- (o) All pulleys with any tension shall not cause the yoke to clamp down on the pulley wheel. Cables to run square in pulleys and not foul on outer casing at any trim angle.
- (p) All pulleys which use an attachment hook of non-ferrous material shall be rejected.
- (q) All attached pulley hooks shall be closed, through bolted and lock nutted.
- (r) Sheathed steering cables shall not be permitted.
- (s) Wires to the steering wheel running across the front of the dashboard shall effectively be shielded.
- (t) It is also recommended that wires running fore and aft inside the cockpit be similarly shielded.
- (u) Jet boats must be fitted with a rudder extending below the bottom of the boat and operating in conjunction with the normal jet steering.
- (v) Teleflex steering shall incorporate dual system unless equipped with power steering (for outboard speed events only).
- (w) Two (2) piece outrigger steering will only be accepted if both halves (wings) are securely joined to each other and braced to power head studs. The outriggers should be sufficiently rigid to prevent undue flexing. It is recommended that stays/supports could be used. All methods of joining cables, pulleys and u-bolts to outrigger wings to have safety cable fitted as per diagram.

**SKI RACING AUSTRALIA (SRA) RULE BOOK
SEASON 2011 – 2012**

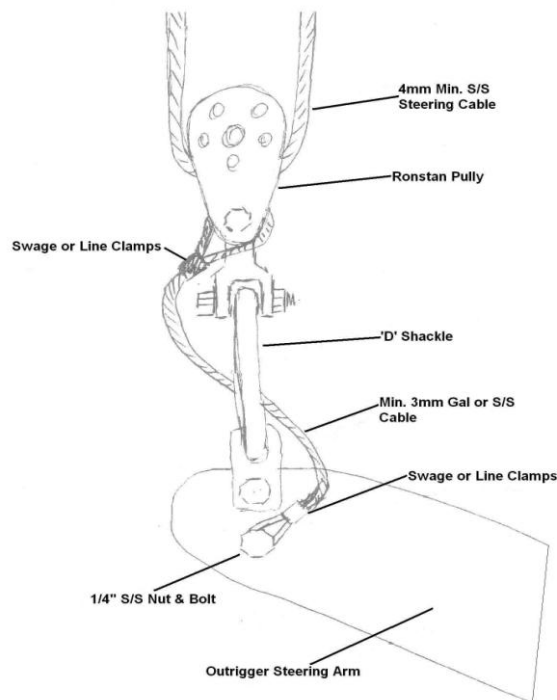

Note: Steering Cable can be gal or stainless steel cable.
4mm minimum.

6mm s/s Nut and Bolt should read 6mm nyloc s/s nut and bolt

- (x) Each boat utilising a cable and pulley system must have a new steering cable at the commencement of the ski race season (July 1st in each year). At the commencement of each ensuing season old cable with seal attached together with new cable fitted to vessel is to be presented for scrutineering and resealing. Rule includes any replacement cable fitted though the season.
- (y) Turnbuckles, minimum size for turnbuckles will be 5/16 or 8mm eye to eye full circle welded both ends

7.15. Steering Relating to Inboard Classes

The rudder shaft on Inboard Classes shall have some type of locking device fitted to prevent the quadrant from moving up the shaft. Rudder shaft to have some type of collar or other preventive measure fitted above cavitation plate or above seal on inboard rudders to prevent rudder dropping. Rudders fitted to inboard boats are to have quadrant and/or arm for steering cables, keyed and lock bolted to rudder shaft with a minimum 6 mm thick key.

7.16. Crack Testing of Rudders

- (a) All rudders are to be engraved or hard stamped on side of blade with boat registration number or state identification number for states where boat registration

**SKI RACING AUSTRALIA (SRA) RULE BOOK
SEASON 2011 – 2012**

does not apply. A current certificate of crack testing to be supplied when boat is scrutineered for new season, i.e. July to June in any given year. A further current certificate must be supplied for replacement rudders.

- (b) All inboards to have a min 1 1/8 inch (28.6mm) rudder shaft size from 6 litre class up (inclusive stock 6lt). From blade through to lower bearing then shaft size may be reduced to fit 1 inch (25.4mm) quadrant.

7.17. Inboards and Outboards welded or repaired below the Cavitation Plate Line

Should any part of the outboard/out drives be welded or repaired below the cavitation plate line, then a certified x-ray to structural integrity is required and must be permanently stamped or engraved on the cavitation housing by the repairer with date of repair for identification purposes. This certification must be renewed every 12 months.

7.18. Control Cables

All control cables shall be taped or screwed down securely.

7.19. Fuel Tanks

- (a) Shall be secure in all directions.
- (b) Shall not leak.
- (c) Shall have sensible filling and venting arrangements where applicable, that are not close to any hot parts, such as exhaust manifolds. As from 1.7.93 all newly manufactured ski-racing boats must have external breathers with fuel fillers deck mounted.
- (d) It is recommended that there should be an easily accessible means of shutting the fuel supply off from the tanks.

7.20. Fuel Lines

Shall be leak and alcohol resistant, and run in a manner to avoid damage. Lines shall be in good condition with proper connectors. Flexible hoses and pipe runs should be clipped up at suitable intervals with fair runs to the engine (at all points of travel in the case of outboards). Lines should be fire-resistant non-collapsing.

SKI RACING AUSTRALIA (SRA) RULE BOOK
SEASON 2011 – 2012

7.21. Throttles and Carburettors

- (a) All throttles must be by foot operation, whether inboard or outboard.
- (b) All carburettors and/or throttles must be spring loaded to close at the engine, and must function accordingly.
- (c) No throttle is to be drive by wire or wireless, unless it can be shown to SRA technical that the throttle WILL close off completely when :
 - Loss of voltage to the system;
 - Total collapse of system;
 - Fusion in the system.

7.22. Extinguisher System

- (a) Approved SAA fire extinguisher must be carried at all times.
- (b) Shall be of satisfactory condition and easily accessible.
- (c) Only fully charged extinguishers shall be permitted and they shall not contain carbon tetrachloride. It is recommended that the extinguisher be capable of putting out a petrol fire at least 4 sq. metres.

7.23. Items to be secured

All component parts of boat such as fuel tanks, batteries and hatches, etc. must be securely fastened in a permanent manner to prevent movement.

7.24. Battery Storage

- (a) Batteries, where carried, shall be easily accessible and prevented from any movement in any direction by means of adequate hold-downs.
All batteries are to have either isolation devices or other means of disconnecting batteries power quickly and be easily accessible by crew. **A blue triangle with yellow lightning bolt battery label identification sticker where isolation switch is fitted.**
- (b) Ensure that there is adequate support below the battery.
- (c) Batteries shall not be placed in a sealed compartment. Commercially available vented battery boxes acceptable.

SKI RACING AUSTRALIA (SRA) RULE BOOK
SEASON 2011 – 2012

7.25. Propellers

- (a) Propeller shall be sound, particularly at the blade roots.
- (b) All propellers to be lock nutted and/or secured by a split pin or locking tab.

7.26. Propeller Shaft

- (a) Propeller shaft to have restraining collar fitted in front of the log.
- (b) Top line shaft (jackshaft) between engine and gearbox or stern leg shall have the slip joint at the engine end. Universal joints in jackshaft to be a minimum 1310 series. Shaft to be a minimum 75mm diameter and have a wall thickness of 0.097 thousands of an inch. Spline drives and greek couplings permitted providing it is suitable for the application.
- (c) External jackshaft cover braces and brackets to suit all applications are compulsory and are to be securely fastened to bearers and through bolted. Recommended that 8-10mm metal/aluminium plate to be used. In manufacturing of a band or bracket to strap around cover suitably positioned as to contain the jackshaft and cover on failure. Top line shaft (jack shaft) covers:
 - Must be a continuous round tubeMaterial thickness:
 - Stainless steel – 1.5mm minimum **this thickness to be increased to 3mm by the start of 2012-2013 season.**
 - Mild steel – 3mm minimum
 - Aluminium extruded tube - 5.5mm minimum
- (d) Common to some inboards with aluminium jackshaft covers. The diagram below is suitable for all applications providing that the appropriate jackshaft size is adhered to as well as clearances. Internal rings must be at least 10mm in section. The drawing is suggested only. Outer tube 3mm minimum working clearance between internal brace and shaft to be no more than 13mm. External jackshaft cover braces to suit application are compulsory. Any other jackshaft cover material (other than aluminium or metal) must be presented to SRA for adjudication.

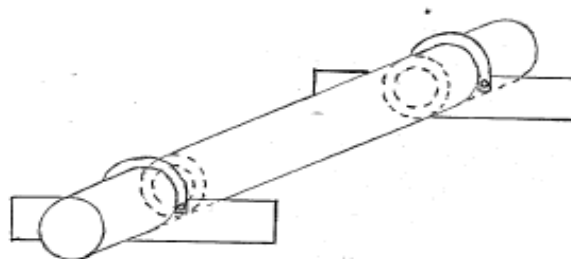

**SKI RACING AUSTRALIA (SRA) RULE BOOK
SEASON 2011 – 2012**

7.27. Refer Rule 7.39

(a) & (b) moved to 7.39 (f) & (g)

7.28. Buoyancy

- (a) All boats shall have sufficient buoyancy to keep afloat in all conditions. Buoyancy aids or material shall be adequately fixed. Scrutineers shall not be responsible for determining the adequacy of the buoyancy in any boat, but may suspend acceptance if in doubt.
- (b) Unless a boat has built in positive buoyancy, the team must demonstrate visually that adequate buoyancy aids have been installed, i.e. that inflated truck tube or similar be secured in bow of vessel.

7.29. Seating

- (a) Adequate seating to be provided for driver and observers. A formed rigid seat with back to be the minimum.
- (b) Seats will be firmly mounted and secured.
- (c) Observer's seat shall face the rear of the boat and be positioned to allow the observer full view of the skiers at all times with the observer remaining seated in the defined observer's seat.
- (d) When back-to-back seating is employed it must conform to the following:
 - i. Boat crew to have working intercom between driver and observer.
 - ii. Be placed centrally within the craft.
 - iii. Not be further apart than 300 mm.

7.30. Cut Out Switch (Jack Plug)

- (a) Cut out switch with cord is compulsory.
- (b) Path and extended length of the cord shall ensure disconnection of the switch when driver unseated or whatever direction of ejection.
- (c) Cord and attachments shall be adequately attached to the cut out switch and the driver's jacket.
- (d) All boats competing in ski racing events must have their fuel pumps rendered inoperative when the cut out switch is activated.

**SKI RACING AUSTRALIA (SRA) RULE BOOK
SEASON 2011 – 2012**

- (e) No device shall be fitted to render the switch plug inoperative.
- (f) Unit shall be attached securely to the boat structure, forward of the backrest of the driver's seat.

7.31. Official Race Numbers

- (a) OFFICIAL NUMBERS shall be those issued by the State Body to the contestants prior to the event. Numbers, number boards, etc. to be supplied by the competitor. Number boards and/or number/s on the side of the boat may be used.
- (b) Numbers on the side of the boat must be displayed in black on a white background by means of waterproof material in such a manner to be visible on both sides of the boat when the boat is on the plane. On a white or light coloured boat a thin-framed edge must be placed around the background and a minimum of 2.5cm from the numbers edge. The minimum dimensions of individual numbers will be 30cm high, 22.5cm wide, 5cm thick and spacing of 12.5cm. However, if hull space permits larger numbers are encouraged. Numbers are limited to a maximum of 3 figures. Numbers on side of boats are to be Helvetica Bold Font with 120% curning. Any variation to be at the race committee's discretion
- (c) Mounting board or backing to be coloured white and to have a clear horizontal visible area from both sides when planing of minimum 35cm high by minimum 45cm wide. Number board or backing to be located on a straight vertical surface. In instances where a straight number board is fitted, it is a requirement that the front leading edge of the number board be rounded and has a minimum diameter of 25mm. Numbers are to be black and a minimum of 25cm high, 15cm wide (except for the number one) and 5cm thick with minimum 5cm clear spacing between each number from all edges of the mounting board. Numbers on number boards are to be Helvetica Bold Font with 120% curning. Any variation to be at the race committee's discretion.
- (d) All numbers/boards to be located above deck or gunwale line and securely fixed to vessel or motor area. Number board to be of a non-translucent material.
- (e) Boats having more than two numbers are to increase mounting board accordingly to achieve the above spacing and size requirements.
- (f) If the number or part of the number comes off or if it is in a position that it cannot be readily identified by the judges then it may cause for a penalty or no time being given.

**SKI RACING AUSTRALIA (SRA) RULE BOOK
SEASON 2011 – 2012**

7.32. Safety Flag

- (a) Safety flag (for downed competitor) must be **bright orange** 50 cm x 50cm fixed to a pole of 1 metre length with a minimum diameter of 16mm, and must be part of equipment. Boat name and registration number must appear on handle.
- (b) A suitable flagpole holder must be provided for use when the skier is in the water and the observer requires both hands for other operations. The safety flag must be in a clearly visible location in all directions when mounted in the pole holder.

7.33. V-Sheets and Blue and White Medical Flag

- (a) A royal blue and white medical flag is to be carried in all boats. Dimensions 50cm x 50 cm fixed to a pole of 1 metre length with a minimum diameter of 16mm. This flag will be 1/2 royal blue and 1/2 white (separated diagonally) on each side (see drawing below). This flag is to be placed in the flagpole holder (after removing the safety flag) only if immediate medical assistance is required. Boat name and registration number must appear on handle.

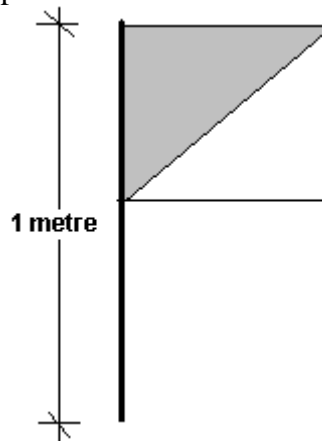

- (b) Boat must carry a safety regulation V-Sheet (minimum size is to be 1.5mtr x 1.0mtr, fluorescent orange with black V. V-Sheet is to be unfolded and spread out on the deck of the boat if medical assistance is required from a helicopter.

7.34. Distress Flares

- (a) Boats must carry a minimum of two SAA Approved coloured daylight smoke flares for ignition, should a member of the crew or competitor be seriously injured, (subject to local governing authority).
- (b) Flares, etc. Normally have stamped expiry date and if they have expired or the date is illegible or the condition poor they shall not be accepted.

**SKI RACING AUSTRALIA (SRA) RULE BOOK
SEASON 2011 – 2012**

7.35. Paddle

- (a) Paddle — not a water ski — shall be stored for immediate use, but not loose.
- (b) The paddle shall be of practical form related to the size of the boat and in useable condition.

7.36. Handholds

All boats must have adequate stationary handhold fixed securely to hull and in a convenient location for observers use at any time. They shall be located to prevent entrapment of boat crew.

7.37. Footrest

All boats are required to have adequate footrests for observer and to be suitably located for bracing observer within seat. They shall be firmly fixed and of such construction that the observer's foot may not be caught underneath.

7.38. Engine Mountings, Transmissions and Lifts for Outboards

- (a) Mounting brackets shall be secure and in a satisfactory condition.
- (b) Engine mountings shall be attached to the transom with at least four (4) bolts. Should an hydraulic lift up plate system be fitted, the mounting plate fixed to the boat must have minimum of 4 bolts fixing mounting plate to boat. The whole moveable motor assembly fixed to the mounting plate must be securely mounted and fitted with safety stops, thus preventing the assembly from parting from the mounting plate or moving up or down beyond design limits. A positive stopper (eg bolt) shall be included to prevent motor upward travel in the event of hydraulic ram failure/breakage.
- (c) All bolts shall be adequately tightened. All bolt heads and nuts must have adequate washers so direct pressure is not placed on surface. All threads of engine mounting bolts to be through/level with nylok/locknuts.
- (d) The engine height of the single outboard on the transom is to be limited to the centre of the prop shaft, no higher than level with the bottom of the hull. (This is measured with the outboard trimmed so the prop shaft is parallel with the bottom of the hull). Hydraulic jacking plate vertical travel must be limited to this height.

**SKI RACING AUSTRALIA (SRA) RULE BOOK
SEASON 2011 – 2012**

7.39. Inboards Requirements

- (a) Engine mountings shall be sound.
- (b) Where an out drive - or jet unit - is fitted, the out drive ring connection to the transom and the unit to the ring shall be secure.
- (c) Transmission and all parts motivated by the engine shall be efficiently shielded so as to prevent damage to persons or structure in the event of breakage. **Exposed steering cables in the vicinity of driver and observer shall be shielded.**
- (d) Bearers shall not be saturated with oil.
- (e) All turbo air intakes must not have any exposed moving parts eg: need to have mesh in front of forward facing air intake trumpets or air filters fitted
- (f) **The boss of the propeller shall have, at all times, some clearance between the rear of the skeg.**
- (g) **All knees, cavitation plates, rudder and skeg are to be secured and without flaws.**

7.40. Engine Condition

- (a) The engine shall be free of dangerous corrosion, oil or fuel leaks or excessive heating and shall not be a danger to any adjacent structure. Oil leaks are a particular source of fire danger.
- (b) For inboard engines, flame arresters are recommended.

7.41. Exhaust Systems

- (a) Exhaust systems shall conform to governing authority's standards of decibels. There shall be adequate insulation where required and runs sited to avoid fire.
- (b) Open exhausts are prohibited.
- (c) Exhaust or trumpets on engine with turbo/forced aspiration are not to face towards skiers.

7.42. Anchor (if required)

Anchor shall be of weight and type adequate to hold the boat. Shall be properly stored to prevent damage, but shall still be accessible.

**SKI RACING AUSTRALIA (SRA) RULE BOOK
SEASON 2011 – 2012**

7.43. Anchor Line (if required)

- (a) Shall be of a size and strength appropriate to the boat.
- (b) Shall be in good condition.
- (c) Shall be at least 35 metres in length.
- (d) Shall be attached at the time of scrutineering, to the boat and the anchor. It shall perform no other function.

7.44. Compasses (if required)

When applicable:-

- (a) Main compass shall be securely mounted and should be able to be read by driver.
- (b) There shall be no large metal objects in the near vicinity of the compass.
- (c) Compass shall be liquid damped and with a rotating card clearly showing the cardinal points.

7.45. Bilge Pump

- (a) Shall be in proper working order and properly secured to the boat.
- (b) Shall be reasonably accessible for operation.
- (c) Shall have a suction pipe to the lowest suction point of the bilges and a discharge pipe overboard.
- (d) It must be possible to pump out all sections of the boat, even if separated by watertight bulkheads.
- (e) No self-draining bung plugs to be used. All bung plugs to be the screw in type.

7.46. Engine Wells

For boats with engine wells, any non-sealed openings, other than self-draining holes in the transom, shall be above a horizontal line through the lowest point of the top of the transom.

**SKI RACING AUSTRALIA (SRA) RULE BOOK
SEASON 2011 – 2012**

7.47. Dry Land Engine Testing

Portable types of safety fences shall be used whilst engines are running with boats on trailers, to protect any person against being injured by moving propellers.

8. CREW AND COMPETITOR REQUIREMENTS AND SAFETY

8.1. Eligibility to Compete

All Crew and Boats entering sanctioned Ski Racing events must be current SRA. members with dues paid and the required documentation received by the Membership Coordinator. This requirement shall be satisfied if the skier or crewmember pays his dues and provides all the required documentation to a SRA official for verification prior to competing.

8.2. Competing Team or Crew

The competing “Team or Crew” shall mean the Driver, Observer and Skier/s.

8.3. Crew Members of the Boat

The crew of the boat consists of a Driver and Observer. No boat competing in an event is allowed further boat crewmembers, unless otherwise approved by the Officials.

8.4. Helmets

- (a) All boat crewmembers competing in events shall be required to wear helmets. Hardhat area of helmet to be bright orange, any faded or non conforming colour must be re-coloured by the next race and noted in the log book. Helmet manufacturer's logo will be the only advertising allowed on helmets, a maximum of 2 no larger than 75 mm x 25 mm each, preferably on the ear cover sections. Competitor's name will be permitted once in letters of 20 mm maximum height 100 mm long at the base or front of the helmet.
- (b) All helmets are to be of an approved type and must be in good condition and devoid of dents and splits. Any holes drilled to improve hearing must not exceed 4mm diameter nor number more than one each side. (This is in order to ensure that the helmet is not weakened).
- (c) Helmet visors shall be in good condition and devoid of cracks and easily detachable (i.e. not bolted down). Visors must not be secured in any way which prevents them lifting up (i.e. taping).

SKI RACING AUSTRALIA (SRA) RULE BOOK
SEASON 2011 – 2012

- (d) The Driver, Observer or passenger must wear helmets that meet Australian standard AS1698. Skier's helmets are NOT to be worn.
- (e) Failure by any team member to correctly wear his helmet whilst under power as a team on race day in the normal accepted manner, may incur a penalty.
- (f) PERMISSION to attach cameras or other devices with the exception of goggles MUST be given by the Chief Scrutineer at classic events or State Scrutineer at other events with notation of approval made in the logbook of each boat the crewmember is in.

8.5. Wearing of Race Gear Following Event

When a boat is on the plane idling back upon completion of an event, no helmets are required to be worn. Unless briefed otherwise.

8.6. Life Jackets

- (a) All boat crewmembers competing in events shall be required to wear a waistcoat type unaltered life jacket with leg straps. Life jackets must be equipped with collars and/or must have flotation material high on the chest to hold an unconscious person's face out of water. Life jackets and life collar, if any, must be securely fastened at all times, while on the course - racing or testing. Leg straps must be securely fastened to life jacket and legs. Cord and attachments shall be adequately attached to the cut out switch and the driver's jacket.
- (b) Life jackets shall also meet the following inspection requirements:-
 - i. Lacing ties and/or straps shall be adequate and in good condition.
 - ii. Zips, where used, shall be in working order.
 - iii. Tears or rents or bad repairs whereby buoyancy will leak out, shall not be permitted.
 - iv. Jackets shall be dry and not oil or waterlogged.
 - v. Jackets shall be fitted with hold-down straps to the legs.
- (c) All self-inflating life jackets should be inspected by the competitor for correct operation prior to each event.
- (d) All life jackets to be predominantly one or more of the following colours – canary, wattle, golden yellow, international orange, scarlet or bright fluorescent colours.
- (e) Self inflating life jackets must not have inner flotation lining removed. It is recommended that inflation canisters be checked before use as per manufacturer's instructions.

**SKI RACING AUSTRALIA (SRA) RULE BOOK
SEASON 2011 – 2012**

8.7. Footwear

Appropriate enclosed footwear must be worn, while in the boat, by drivers and observers.

8.8. Fire Suits

- (a) All boat crew members shall be required to wear a driving suit that covers from neck to ankle with long sleeves. **Minimum standard of a single layer clubman style with a rating of SF13-2A/1**
- (b) 60 mph class - 1st year competitors are not required to comply with this rule, however, are required to wear, full covered cotton overalls long sleeve full leg.

8.9. Boat Testing and Unofficial Practice

When boat testing and in unofficial practice all crewmembers must wear all safety equipment.

8.10. First Aid Awareness

Competitors over the age of 13 years of age are required to attend a CPR practical training session every 4 years or upon joining, with a cut off date of June 30th, and with an online test to be completed every 12 months

SRA will also accept CPR and first aid certificates that are conducted for employment purposes.

8.11. Safety Belts

Safety Belts are not permitted.

8.12. Boat Drivers and Observers

- (a) All drivers must hold a current Boat Driver's Licence where applicable, as specified by the Controlling Government Body and must have attained the age of 18 years.
- (b) In addition, any driver residing in a Country or State whose Government controls the issue of Boat Drivers' Licences, shall not be permitted to compete in a race unless he has possession of such a licence.
- (c) Drivers and observers must hold a current **SRA** approved Ski Racing Licence. All states will recognise and accept other states' ski racing drivers' licences.

**SKI RACING AUSTRALIA (SRA) RULE BOOK
SEASON 2011 – 2012**

- (d) Required minimum age for an observer is 16 years.
- (e) Drivers and observers must hold a current approved Medical Certificate, medical examination to be carried out by a medical practitioner at least every two years.
- (f) Drivers and observers must be completely conversant with the SRA Ski Racing Rules.
- (g) Each State will adopt and implement, as a minimum requirement, a 2 Stage Licensing System. This system will be applicable to both new Drivers, and Drivers returning following a period of **2 years** or more where they have not been competing.

8.13. Skiers

- (a) All external surfaces of the hard helmet shell shall be fluorescent orange, in the case of soft outer covered helmets they shall be fluorescent orange with the exception of the chin and goggle securing straps and mauser joining tape.
- (b) Helmets to have:-
 - i. Cover for the ears to prevent ruptured eardrums when the head hits the water in a sideways fall. When soft ear covers are added to a helmet they may be a different colour e.g. black, etc.
 - ii. A secure and close fit on the head to reduce the possibility of “bucketing” or forcing water between the helmet and the head.
 - iii. Secure straps - correctly adjusted. “D” Clips must not be used as a means of fastening or adjusting skiers’ helmets.
 - iv. The helmet must float and be adequately constructed to absorb impact.
 - v. Helmet manufacturers’ logos will be the only identification allowed on helmets, a maximum of two (2) no larger than 75mm x 25mm each, preferably on the ear cover sections. Competitor's name will be permitted once in letters of 20 mm maximum height 100 mm long at the base of the helmet.

8.14. Helmets to be worn on race day and practice.

All team members shall wear their helmets in the normally accepted manner during the race and whilst under power on race day or practice periods. Failure by any team member to correctly wear his/her helmet whilst under power on race day, may incur a penalty. When a boat is on the plane idling back upon completion of an event, no helmets are required to be worn.

**SKI RACING AUSTRALIA (SRA) RULE BOOK
SEASON 2011 – 2012**

8.15. Buoyancy Vests

- (a) Approved buoyancy vests must comply with a minimum PFD2 Australian standard and must be worn by all competitors, these to be predominantly one or more of the following colours — canary, wattle, golden yellow, international orange, scarlet or bright fluorescent colours. A wet suit or belt shall not be considered to be an adequate buoyancy vest. Vests must have two straps completely encircling the body. Crutch straps are compulsory except in Marathons.
- (b) If a wet suit is worn over a vest, crutch straps are not necessary. Wet suit must be one or more of the following colours — canary, wattle, and golden yellow, international orange, scarlet or bright fluorescent colours.
- (c) SRA approved ski racing wet suits with built-in flotation will be accepted provided they comply with a minimum PFD2 Australian standard and that the top section from the armpits up, is one or more of the following colours — canary, wattle, golden yellow, international orange, scarlet or bright fluorescent colours and have three safety straps over the opening area. It is desirable but not mandatory that the safety straps be one of the aforementioned colours. All recommended colours must be still visibly bright when wet. Underarm gussets, zippers, mauser tape on seams and edging can be any colour.
- (d) Skiers are allowed to wear long sleeved rash vests these must be 100% in bright fluorescent colours as per (c) above.
- (e) Safety water ski trunks with manufactured, unaltered leg straps may be acceptable.
- (f) Buoyancy vests shall also meet the following inspection requirements:-
 - i Lacing ties and/or straps shall be adequate and in good condition.
 - ii. Zips, where used, shall be in working order.
 - iii. Tears or rips or bad repairs whereby buoyancy will leak out, shall not be permitted.
 - iv. Jackets shall be dry and not oil or waterlogged.
 - v. Jackets shall be fitted with hold-down straps to the legs.
- (g) SRA has the right to test floatation of equipment following the Australian Standards Testing procedure known as “Swim Test”
 - i The wearer is to be the owner of the wet suit and is positioned in water deeper than the height of the wearer.
 - ii. Body position is straight up and down with legs below but free of the bottom.
 - iii. Arms are to be beside the wearer’s body. The wearer has to relax and not work against the suit.
 - iv. The wearer is to exhale all the air out of their lungs.

SKI RACING AUSTRALIA (SRA) RULE BOOK
SEASON 2011 – 2012

- v. The outcome of test is that the suit will keep the wearer afloat with their mouth well clear of the water with exhaled breath. The suit must also have a bias to float the wearer towards their back. Under no circumstances should the suit float the wearer towards their face
- vi If the wetsuit floatation is not sufficient a fluorescent life jacket with leg straps must be worn over the wetsuit

8.16. Use of Water Bottles and the like

Water bottles and the like (Camel Backs) may be worn for hydration purposes and shall be made of a soft material e.g. made of wetsuit material. These must be worn on the back, but must not be worn under the safety straps of the race suit. If the container is housed in an integral pouch as part of the wet suit, the safety straps of the wet suit must pass under the pouch and not around the pouch. All stoppers must be of soft plastic material. The drinking tube is to be long enough to reach the mouth but not long enough to reach the eyes. These devices must be checked by the chief scrutineer at classic events or state scrutineer at other events with notation of approval made in the logbook of each boat the skier skis with.

8.17. Clinch Gloves

Clinch type gloves are not permitted.

8.18. Taping of Ski Bindings

- (a) Competitors may only tape ski binding externally as an aid to deflect water or stop buckles from coming loose. Maximum 50mm up side of binding. See diagram below.

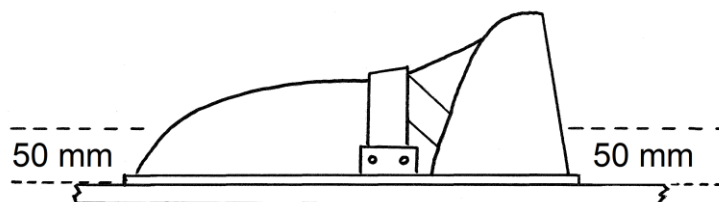

- (b) Competitors may tape lower legs, feet or ankles, but not in a manner that would stop their feet coming free of the ski bindings in the case of a fall. Legs, ankles or feet must not be taped directly to either the ski or bindings. Any type of harness to stop free movement of legs, ankles or feet is prohibited.
- (c) Bindings that are designed to detach from the ski in the event of a fall are permitted.

**SKI RACING AUSTRALIA (SRA) RULE BOOK
SEASON 2011 – 2012**

8.19. Skis

- (a) A coloured fluorescent orange paint or adhesive tape at least 15cm in length must be placed on the upper and lower front tip of all skis with a maximum 5mm margin permissible around the perimeter of the ski. Manufacturers' logo must be under the 15cm area.
- (b) Either one or two skis may be used, and such skis must be in a serviceable condition.
- (c) Skis shall not be more than 3 metres in length.

8.20. Marathon Skis

- (a) Marathon skis are defined as follows:
- (b) Any type of binders and fins are allowed except in events specifying skis without such fittings.
- (c) A finless ski shall conform to (a), (b), (c) and (d) but no fins are allowable.
- (d) A freeboard ski shall conform to (a), (b) and (c) but no binders are allowed. Fins are mandatory on the underneath surface of ski, but the top surface of the ski must be smooth and without indentation, roughened surfaces are allowable with equal density but must be continuous. Drop through fins must be flush.
- (e) A plank shall not exceed 155cm in length, 15cm wide, 2cm thick, square on all edges, bare on both sides, of consistent texture on all surfaces, no sand or indentations - straight with 1.25cm tolerance concave over full length. No turn up at ends, no tapers or bevels, no round edges or ends, no fins, fittings or binders. See illustration below.

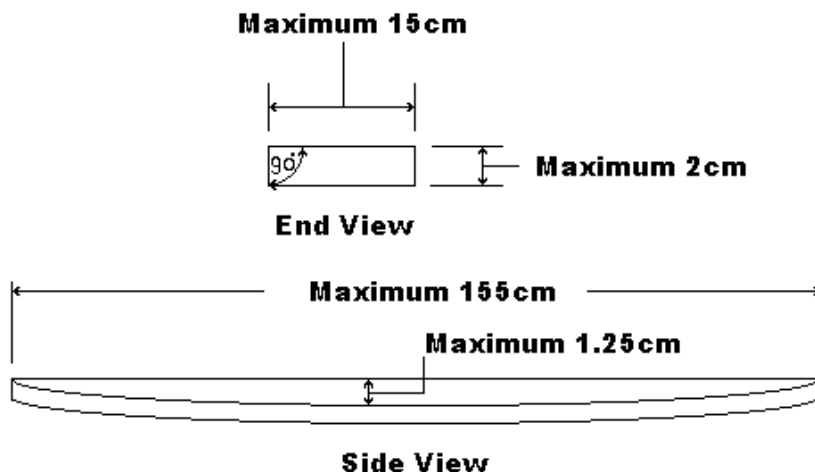

**SKI RACING AUSTRALIA (SRA) RULE BOOK
SEASON 2011 – 2012**

8.21. Non-conformity with the Rules

A competitor wishing to use any equipment that does not comply with these above rules, may submit a sample to the Race Committee for determination at least four weeks prior to the event.

8.22. Tow Lines

- (a) The skier shall provide towlines, preferably of polythene or polypropylene material. No harness is to be used. A harness is defined as any device that is not permanently attached to the towline, the only exception to this rule will be for disabled skiers, who will be assessed on a case-by-case basis.
- (b) The minimum length of a towline is 21 metres, including handles and skier's bridle.
- (c) The maximum length of a towline is unlimited, providing safety limitations are maintained.

9. BOAT TECHNICAL REQUIREMENTS

9.1. Boat Measurements

- (a) Boat used for towing skiers must not exceed 6.5 meters in overall length. The overall length is measured between the two perpendiculars, one at the bow of the boat (A), the other at the point where the bottom intercepts the transom (B). (See diagram #1). Intersection of keel and transom is key to all other measurements.
- (b) An extension shall be for the purpose of mounting an outboard motor(s) or a drive leg(s) to the transom of the boat used for towing skiers. The extension can be attached as a fabricated bracket and bolted to the transom or it can be molded to the transom of the boat used for towing skiers. Maximum length of the extensions and power unit(s) combined shall be 1.4 meters. There is a minimum dimension of 150mm (6") measured from the lowest part of the extension to the intersection of the bottom of the boat to the transom, or the projected line of the transom if it does not continue to the bottom of the hull. No part of the extension shall be in the water while the boat towing skiers is on plane.
- (c) No "COSMETIC" extensions or protrusions are allowed in the 150mm (6") NO GO ZONE. (See drawing #2—View to transom) Adjustable trim tabs ARE allowed in this 150mm (6") NO GO ZONE.

**SKI RACING AUSTRALIA (SRA) RULE BOOK
SEASON 2011 – 2012**

- (d) The length of the outward chine shall be limited to 6.60 m in overall length (A to B-1 see drawing #1). This allows for some design in the outward angle of the transom, the additional .10 m is equal to 3.937 inches.

Drawing #2 with top views, side view and view to transom are part of this rule. B – C is defined as ---Transom to propulsion point (e.g. end of propeller shaft, nozzle of jet unit, 1.4 m).

- (e) Boats competing in worlds competition need to conform to IWWF rules as per current IWWF rule book.

**SKI RACING AUSTRALIA (SRA) RULE BOOK
SEASON 2011 – 2012**

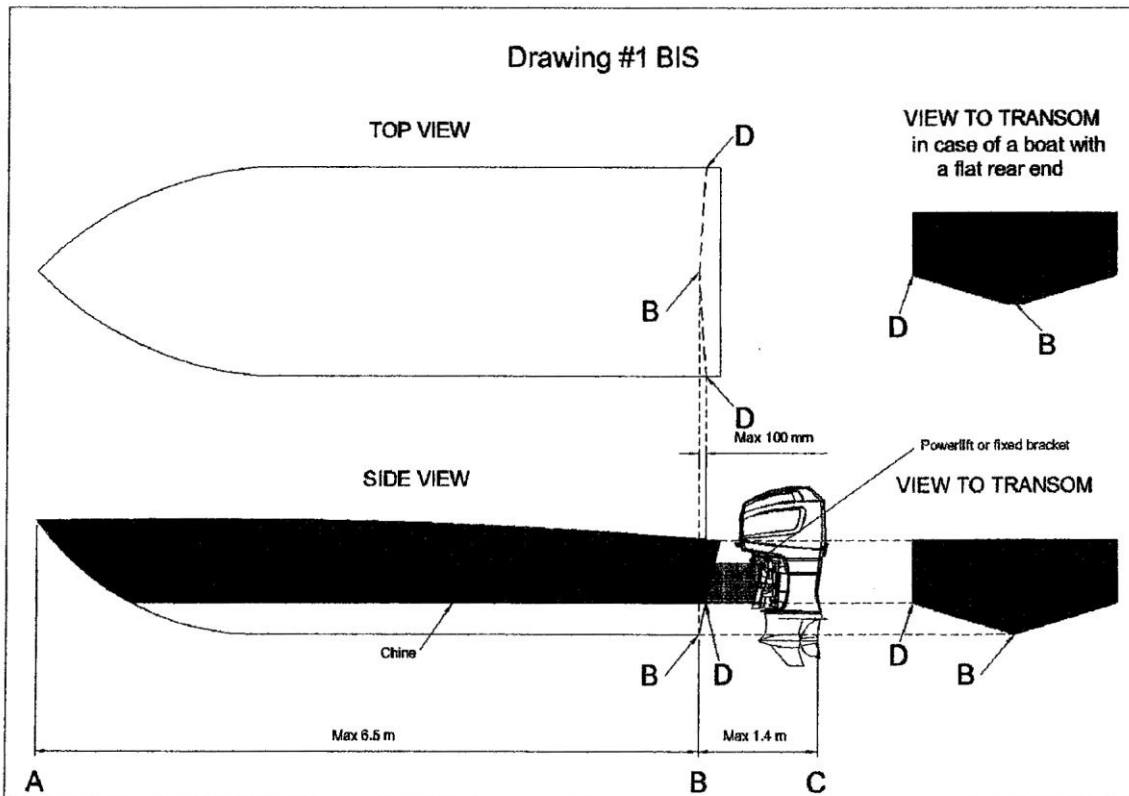
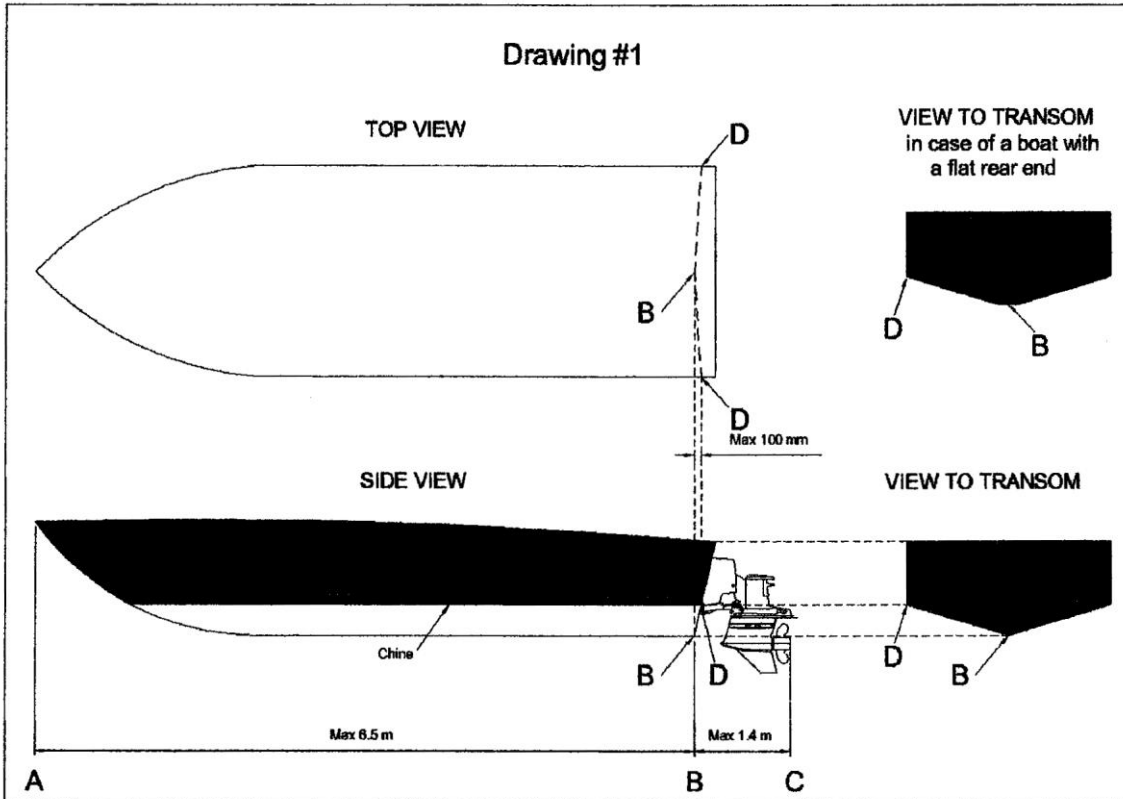

**SKI RACING AUSTRALIA (SRA) RULE BOOK
SEASON 2011 – 2012**

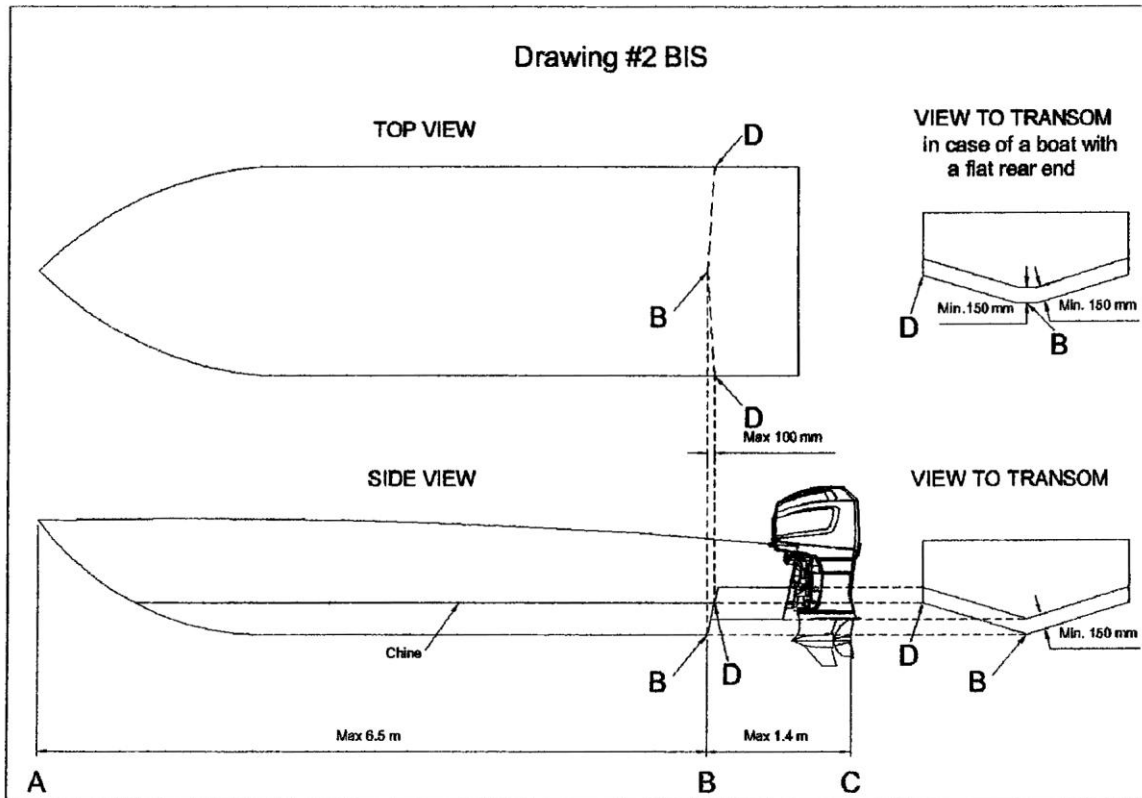
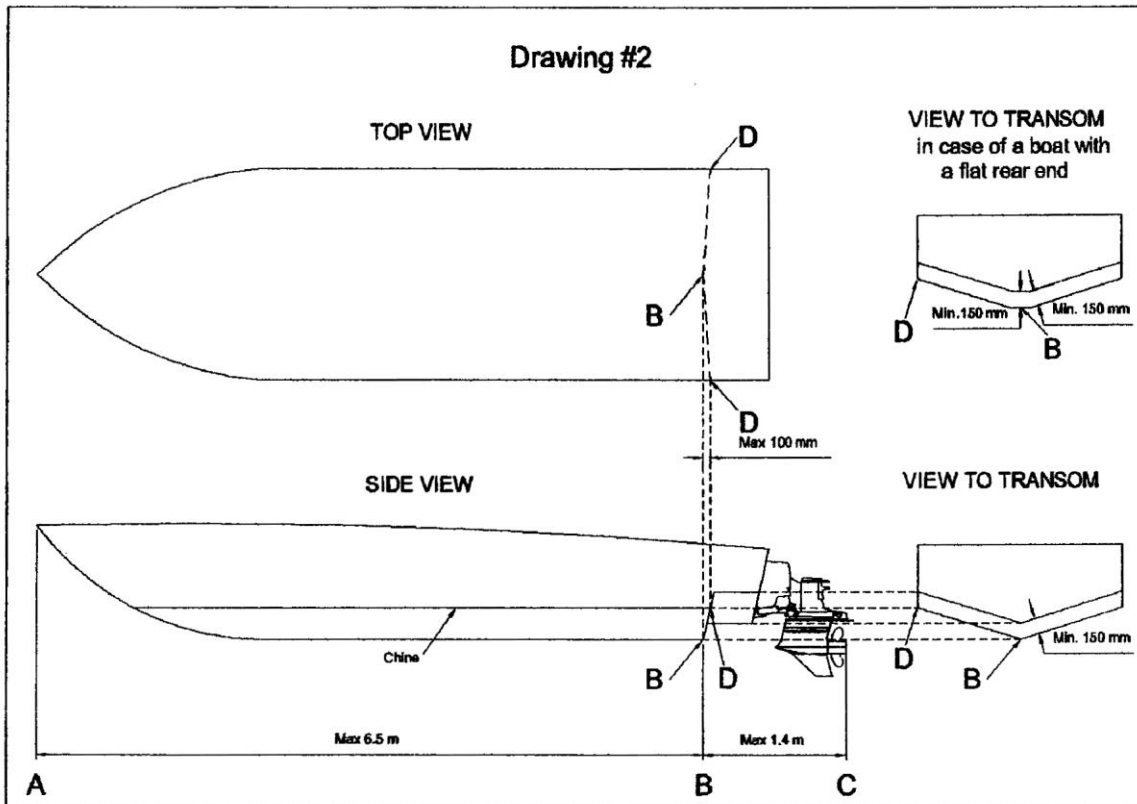

**SKI RACING AUSTRALIA (SRA) RULE BOOK
SEASON 2011 – 2012**

9.2. Measuring and Sealing of Engines

**ALL ENGINE CLASSES MUST BE SEALED BY SRA APPROVED
ENGINE SEALERS BEFORE COMPETING.**

- (a) Names of SRA approved sealers are available from the SRA office. Exception to this rule applies to MOC, Unlimited Outboard, 60mph and 70mph.
- (b) Sealing paper work to accompany the boat and log book at all times.
- (c) All outboard engines that have to be sealed are to have a minimum of 3 seals (1 – induction inlet manifold to crankcase, 1- head sealed & 1 – engine block so that it cannot be removed from exhaust plate).
- (d) All inboard engines except for stock are to have a minimum of 1 seal to be attached to the timing cover bolts or so the crank shaft cannot be replaced.
- (e) Stock inboard – minimum of 3 seals on timing cover bolts, inlet manifold bolts & Carburettor bolts.

9.3. Modifications

- (a) All inboard classes except Stock allowed unlimited modification provided capacity adhered to.
- (b) Inboard hydroplanes, tunnel hulls, jet boats and those with outboard legs will enter inboard engine capacity.

9.4. Stock Inboard Rules

ENGINE

- (a) **Small block:** Under 6 Litre with a small block configuration.
 - i. Engine blocks to be cast iron construction.
 - ii. Bore size not to exceed 4.080 inches maximum for all engines.
 - iii. Connecting rods must be of magnetic material. No exotic materials, eg. titanium.
 - iv. Connecting rods not to exceed 6 inches in length, centre to centre.
- (b) **Fuel** - ONLY commercially available automotive premium/unleaded pump fuel from service stations permitted.
 - i. No racing fuels, AV gas or imported unleaded fuel from overseas or any fuels that contain MTBE (eg VP, Unical, Elf, Sunoco, etc).

**SKI RACING AUSTRALIA (SRA) RULE BOOK
SEASON 2011 – 2012**

- ii. No nitrous oxide or gases of any sort.
 - iii. No additives or octane boosters.
- (c) **Carburettor** - must be a Holley 4777 series.
- i. The only alterations permitted to the carburettor is the changing of jets, needle and seats, power valves and the removal of all or part of the choke mechanism. No machining or removal of metal from the carburettor body is permitted.
 - ii. All air supplying the engine must pass through carburettor venturis, no breathers or PCV valves to be fed below venturis.
- (d) **Manifolds** - Inlet manifolds must be commercially available, of cast construction, single or dual plane. Fabricated or sheet metal manifolds are not permitted.
- i. Manifold plenum and port runners must remain as cast. No porting or port matching of any kind permitted.
 - ii. No ceramic or other coatings inside manifolds permitted;
 - iii. Spaces and gaskets combined must not exceed 182mm in total combined height. Combined height is measured from the manifold sealing surface of the engine block to the underside of the straight edge placed on the manifold/spacer carburettor mounting base. Calculate example: if A-170mm and B-190mm (170 + 190 - 360mm) divided by 2 = 180mm total combined height. See diagram below:

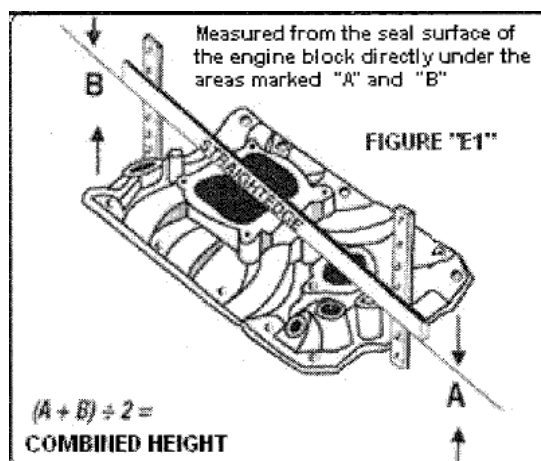

- (e) No means of forced induction.
- (f) **Exhausts** - Restrictions to exhaust systems are as follows:
 - i. Each bank of cylinders shall have 1 only tail pipe and ALL exhaust gas from each bank of cylinders shall pass through this pipe, no 8 into 1 extractors.
Other than that exhausts are free.
 - ii. Exhaust systems must comply with noise levels as per SRA rule 7.40.

SKI RACING AUSTRALIA (SRA) RULE BOOK
SEASON 2011 – 2012

- (g) **Camshaft** - flat tappet camshaft only. Original engine manufacturers (OEM) bore size for lifters.
- i. No Schubeck style lifters or exotic materials.
 - ii. Must be of magnetic body and face.
 - iii. No mushroom style lifters of any sort permissible.
 - iv. Camshaft drives of any type are permitted.
- (h) **Rocker** - Roller rockers permissible.
- i. Standard OEM ratio to be maintained. GM (Chev) 1.50 / GMH (Holden) 1.65 / Ford (Boss/Chev) 1.73 / Ford (Windsor) 1.60 / Chrysler 1.50..
 - ii. Only single stud mounted rockers allowed (stud must be in OEM position).
 - iii. No shaft mounted rockers (eg: Jessel or T&D).
- (i) **Heads** - Cylinder heads must be of cast iron construction and commercially available. Cylinder heads must maintain original valve to block angles, plus or minus 1 degree for all mass production small block engine specifications available pre 1994. For example Chev 23 degree heads only.
- i. Port height. Bolt hole centreline to inlet port roof, floor, height of port and width of port. See diagram below. All measurements to have a 1% tolerance.
 - ii. Valve seats may be reclaimed with the use of new inserts, valve guides are free
 - iii. Match porting of inlet and exhaust ports of cylinder head permitted to be machined to a distance of 13mm towards the valve to match manifolds.
 - iv. Valve size free, however original valve seat angles must be maintained.
 - v. Surface grinding permitted, however original angle must be maintained.
 - vi. No other machining, porting or modifying permitted apart from machining screw in studs and valve spring seats.

**SKI RACING AUSTRALIA (SRA) RULE BOOK
SEASON 2011 – 2012**

Head flange view.

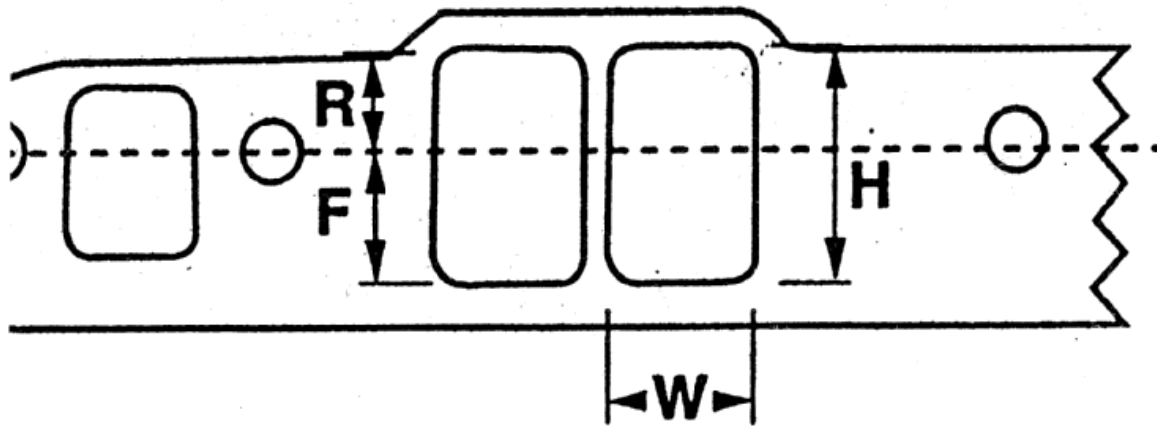

Chevrolet: R = 0.980 inches
F = 1.250 inches
H = 2.230 inches
W = 1.310 inches

Holden: R = 1.220 inches
F = 1.340 inches
H = 2.560 inches
W = 1.260 inches

Ford Cleveland R = 1.450 inches
F = 1.200 inches
H = 2.650 inches
W = 1.850 inches

Ford Windsor R = 1.030 inches
F = 1.040 inches
H = 2.070 inches
W = 1.280 inches

Chrysler R = 1.100
F = 0.910
H = 2.010
W = 1.030

- (j) **Flywheel** - Steel or aluminium billet construction.
 - i. No cast or cast aluminium flywheels.
- (k) Maximum static compression ratio 10.5 to 1..
- (l) **Pistons** - Flat top or concave only.
 - i. Must not protrude past top of cylinder block
- (m) **Wet sump only**, sump configuration and capacity free.
 - i. Oil pump to remain in original position. Can be of higher volume and capacity.
 - ii. No dry sump systems.
- (n) Standard ignition or electronic ignition, single coil.
 - i. No magnetos or crank trigger systems.

**SKI RACING AUSTRALIA (SRA) RULE BOOK
SEASON 2011 – 2012**

- (o) **Stern Drives** - All standard production stern drives allowed, no modifications permitted. Torque tamers allowed.
- i. Any size leg permitted.
 - ii. No racing legs permitted.
 - iii. Nose cones are permitted.
 - iv. Stand off boxes is permitted. No stern jacks permitted.
 - v. Transom or leg mounted pickups for showers are permitted.
 - vi. Water pickup must be operational.
 - vii. If using "Bravo" leg OEM replacement prop shaft allowed.
- (t) **Spirit of the Class**
The spirit of the stock inboard class is to provide ski racing at reasonable cost. Anything not covered or is outside of the rules is not permissible. However, acknowledging that there will be circumstances where the unforeseen will occur, appeals and/or grievances and/or rule modifications may be lodged with the SRA Technical Committee who will assess the matter and advise the SRA Board accordingly and seek the final decision on the matter from the SRA Board.

9.5. Single Engine Outboard

The height of the outboard on the transom is to be limited to the centre of the prop shaft, no higher than level with the bottom of the hull. (This is measured with the outboard trimmed so the prop shaft is parallel with the bottom of the hull). Hydraulic jacking plates operated from the cockpit must have vertical travel stops that are of a construction that that form a positive stop and must limit prop shaft to this height.

9.6. 200Hp Outboard

- (a) Standard Motor Definition applies – refer section 9.9
- (b) Maximum manufacturer/official rating of 200 Horse Power.
- (c) Forced Induction only allowable on Mercury Verado 4 cyl engines. Mercury Verado 6 cyl and any other engines that employ forced induction are not permitted in this class.
- (d) Engines manufactured in 2001 and onwards must be approved by SRA. Currently SRA approved 2001 and onwards engines for 200Hp Outboard are:
- Mercury 200xs
 - Mercury 200 Pro XS
 - Evinrude 200 HO
 - Evinrude 200
 - Mercury 200 Verado (4 Cylinder model)

**SKI RACING AUSTRALIA (SRA) RULE BOOK
SEASON 2011 – 2012**

9.7. S.M.O.C. – Standard Motor Open Cockpit

- (a) Standard Motor definition applies – refer section 9.9.
- (b) Maximum of 250 Advertised Horse Power
- (c) Open Cockpit Hull Definition applies – refer section 9.10.
- (d) Engines manufactured in 2001 and onwards must be approved by SRA.
SRA reserves the right to approve or not approve any new engine.
Current SRA approved 2001 and onwards engines for SMOC are :
 - Mercury 250xs / 250pro xs **allowable gearboxes are sportmaster, torquemaster, fleetmaster and verado style.**
 - Mercury Verado 250 **allowable gearboxes verado style gearbox.**
 - Evinrude 225HO / 250HO **allowable gearboxes include L1, L2, M1 and M2 Types.**
 - Yamaha VF250LA 20inch trunk
 - Suzuki DF250SS 20inch trunk
- (e) Optional or special order parts are not allowed in standard outboard engine classes

9.8. M.O.C. – Modified Open Cockpit

- (a) All engines must have operational forward, neutral and reverse and to be controlled from the drivers position.
- (b) Engine modifications are acceptable.
- (c) No turbo charging, super charging or nitrous oxide allowed. Exceptions – refer to 9.8 (e).
- (d) Maximum of 3.5 litre engine capacity. **Exceptions – refer to 9.8 (e).**
- (e) **Any engine that is approved and legal to run in SMOC and/or F2 class and that has been sealed by SRA to compete in these classes can compete in MOC class.**

**SKI RACING AUSTRALIA (SRA) RULE BOOK
SEASON 2011 – 2012**

9.9. Definition of a Standard Outboard

9.9.1 Engines Manufactured in 2000 and prior

- (a) Engine must be a standard production engine, mass produced and freely available to the public via any dealership. This means engines sold via specialised dealers only, or only available in restricted or limited volume are not eligible.
- (b) All engines must carry original manufacturer model number and serial ID plates, sticker, etc. These will be located on the engine. Loss of this information will mean the competitor will have to apply through SRA Board to have this information reinstated and verified before competing.
- (d) The upgrading of engines from their original year specification will not be accepted.
- (e) The factory super session of parts is acceptable.
- (f) The fitting of earlier model parts or back fitting is not acceptable.
- (g) Aftermarket parts other than permitted parts will have to be verified by SRA Technical committee prior to competition.
- (h) Tell tales can be moved to observer's side. Tell tale must reflect same diameter as original OEM tell tale.
- (i) Exceptions. Spark plugs, propellers carburettor jets, ignition timing, nose cone torque tamers, reeds, oil injection pumps can be removed as a safety measure - this includes lines and receivers, rev limiter can be disconnected, one piece drive shaft, one piece prop shaft allowed.
- (j) Fuel pumps. Electric fuel pumps are acceptable provided fuel passes through the original unaltered fuel pump onto engine and is operational. The electric pump must turn off with cut out switch.
- (k) Gear Box. (refer to Amendments page)
 - i. The permitted fitting of nose cones is not to include additional fluting to aid water pick up. The fitting of the nose cone will not compromise the original contour of the gearbox. Water pick ups are not permitted to be blocked off or restricted and must not compromise the visual existence of the inlet holes from standard.

**SKI RACING AUSTRALIA (SRA) RULE BOOK
SEASON 2011 – 2012**

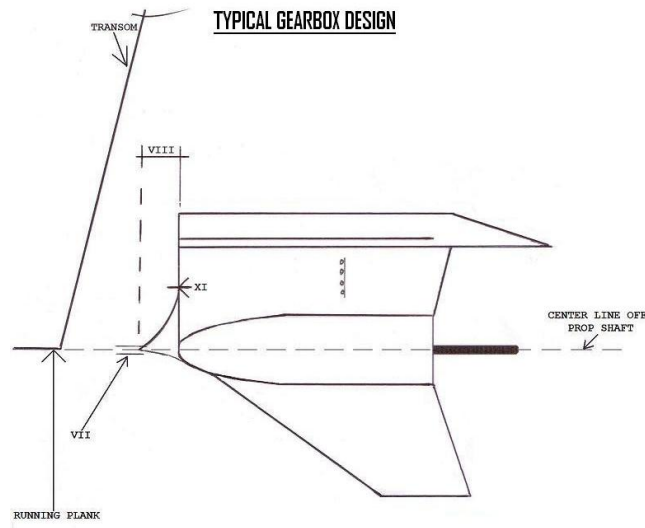

- ii. Welded propellers must supply crack test certificate every 12 months.
 - iii. Single propeller systems only.
 - iv. Removal of metal from skeg not permitted.
 - v. Gear box must have correct ratio gear set in for that model.
 - vi. Gear box must have forward, neutral, reverse and be controlled from the cockpit.
 - vii. Nose cone point or tip to be plus or minus 8mm from centre line of prop shaft.
 - viii. Overall measurement of standard gearbox measured from rear of gearbox housing to leading tip of gearbox may not be increased by more the 100mm by the fitting of any nose cone.
 - ix. Skeg to have no metal removed from original. Torque tamers allowed. Damaged skegs to be rebuilt – refer 7.17
 - x. Welded nose cones are permissible – refer 7.17.
 - xi. Nose cone not to extend more than 200mm above prop shaft centre line vertically.
 - xii. Cavitation plate on gearbox to have no metal added or removed.
 - xiii. One piece drive shafts allowable.
- (l) Power Head.
- i. No changes to manufacturer's specifications are allowed.
 - ii. No metal is to be added.
 - iii. No metal is to be removed, except for normal reconditioning
 - iv. No modifications to exhaust tuner and/or exhaust reliefs.
 - v. All wiring looms must ID that particular model and serial no.
- (m) Electronics.
- i. Piggy back computer to aid engine computer is not permitted.

**SKI RACING AUSTRALIA (SRA) RULE BOOK
SEASON 2011 – 2012**

- ii. Drive by wire. No steering is to be drive by wire or wireless. No throttle is to be drive by wire or wireless, unless it can be shown to SRA technical that the throttle **WILL** close off completely when:
 - Loss of voltage to the system;
 - Total collapse of system;
 - Fusion in the system.Gearshift by wire or wireless is acceptable.

- (n) Fuel.
 - i. Unleaded or premium unleaded only.
 - ii. Fuels containing MTBE strictly prohibited.

- (o) Anything not covered or outside the above rule cannot be done, however, due to the unforeseen, appeals will be given consideration by SRA technical and then passed to the SRA board for final decision.

- (p) Spirit of the class - Standard manufactured outboard engines racing in controlled formulae.

9.9.2 Engines Manufactured in 2001 and onwards

- (a) Engine must be a standard production engine, mass produced and freely available to the public. This means engines sold via specialised dealers only, or only available in restricted or limited volume are not eligible.

- (b) All engines must carry original manufacturer model number and serial ID plates, sticker, etc. These will be located on the engine. Loss of this information will mean the competitor will have to apply through SRA Board to have this information re-instated and verified before competing.

- (c) The upgrading of engines from their original year specification will not be accepted.

- (d) The factory supersession of parts is acceptable.

- (e) The fitting of earlier model parts or back fitting is not acceptable.

- (f) Aftermarket parts other than permitted parts will have to be verified by SRA Technical committee prior to competition.

- (h) Exceptions; propellers, nose cone, torque tamers and spark plugs.

- (i) Fuel pumps. Electric fuel pumps are acceptable provided fuel passes through the original unaltered fuel system. The electric pump must turn off with cut out switch.

**SKI RACING AUSTRALIA (SRA) RULE BOOK
SEASON 2011 – 2012**

- (j) Gear Box.
- i. Nose cones are permitted; however are not to include additional fluting to aid water pick up. The fitting of the nose cone will not compromise the original contour of the gearbox. Water pick ups are not permitted to be blocked off or restricted and must not compromise the visual existence of the inlet holes from standard.
 - ii. Welded propellers must supply crack test certificate every 12 months.
 - iii. Single propeller systems only.
 - iv. Removal of metal from skeg not permitted.
 - v. Gear box must have correct ratio gear set for that model.
 - vi. Gear box must have forward, neutral, reverse and be controlled from the cockpit.
 - vii. Nose cone point or tip to be plus or minus 8mm from centre line of prop shaft.
 - viii. Overall measurement of standard gearbox measured from rear of gearbox housing to leading tip of gearbox may not be increased by more than 100mm by the fitting of any nose cone.
 - ix. Skeg to have no metal removed from original. Torque tamers allowed. Damaged skegs to be rebuilt - Refer 7.17.
 - x. Welded nose cones are permissible – Refer 7.17.
 - xi. Nose cone not to extend more than 200mm above prop shaft centre line vertically.
 - xii. Cavitation plate on gearbox to have no metal added or removed.
- (j) Power Head.
- i. No changes to manufacturer's specifications are allowed.
 - ii. No metal is to be added.
 - iii. No metal is to be removed, except for normal reconditioning
 - iv. No modifications to exhaust tuner and/or exhaust reliefs.
 - v. All wiring looms must ID that particular model and serial no.
- (k) Electronics.
- i. Original factory Engine Management Systems to remain in **place unaltered and to retain standard manufactures engine software settings. Manufacture service updates accepted.**
 - ii. Piggy back computer is not permitted.
 - iii. Drive by wire. No steering is to be drive by wire or wireless. No throttle is to be drive by wire or wireless, unless it can be shown to SRA technical that the throttle **WILL** close off completely when:
 - Loss of voltage to the system;
 - Total collapse of system;
 - Fusion in the system.Gearshift by wire or wireless is acceptable.

**SKI RACING AUSTRALIA (SRA) RULE BOOK
SEASON 2011 – 2012**

- (l) Fuel.
 - i. Unleaded pump fuel only.
 - ii. Fuels containing MBTE strictly prohibited.
- (m) Anything not covered or outside the above rule cannot be done, however, due to the unforeseen, appeals will be given consideration by SRA technical and then passed to the SRA board for final decision.
- (n) Spirit of the class - Standard manufactured outboard engines racing in controlled formulae.

9.10. Definition of an Open Cockpit Hull

- (a) Hull must be factory production model sold or advertised through normal channels.
- (b) Light lay-ups from factory will be allowed.
- (c) Centre steering will not be allowed.
- (d) Motors exceeding 200 kilos in weight will not be permitted on boats with length less than 17 feet, 5.182 metres in length.
- (e) Cockpit size shall be of length 1680 mm measured at floor level and width of 1170 mm measured at floor level.
- (f) Observers seat will be next to or in front of the drivers seat. No part of the observers seat shall extend past the rear of the drivers seat
- (g) Mod V.P.'s to be included.

9.11. Post Race Technical Scrutineering

- (a) All competitors are to have boats available for engine scrutineering when requested by race or technical committee.
- (b) Red tag may be applied by the direction of chief scrutineer and or level 1 techo to any item that consider outside the rule book and needs further special investigation away from race venue. This includes the ability to remove or replace any component of the engine. Red tag may only be removed by engine sealer who must conduct full report in writing to be supplied to chief scrutineer and tech directors of National & State bodies. Removal of red tag by other than registered sealer will result in disqualification. Failing to report to have seal removed/Inspected –disqualification. Competitor to pay costs if investigation failed. Failure to comply with any direction from tech/srutineer – disqualification.

**SKI RACING AUSTRALIA (SRA) RULE BOOK
SEASON 2011 – 2012**

- (c) Any boat failing to be presented, upon request, to post race technical scrutineering will be disqualified from that event and any future entries will not be accepted for that class until the engine has been scrutineered and sealed to conform to the rules of that class.
- (d) Competitors found to have boats outside these rules will be liable for penalties. These penalties will apply to:
 - i Boat owner;
 - ii Engine Builder;
 - iii Driver.
 - iv **Boat**
- (e) Should the engine have been sealed outside these rules, the sealer will be stood down pending an investigation by SRA.
- (f) Penalties for breach of scrutineering rules **and/or tampering of seals:**
Up to a **maximum of** 12 months ban for owner, driver **and boat**. This ban will be effective immediately, pending investigation by SRA Officials;
Lifetime ban, never to hold the position again, for engine sealers.
- (g) Protest. In the case of competitor protesting against another competitor wanting the engine reviewed, the competitor must lodge \$1500.00 with the Chief Judge in addition to the protest fee. Should the protest prove valid the funds will be returned. If the protest fails the funds will go to the competitor to pay for the reassembly of the engine in question.
- (h) **All Appeals to be lodged to SRA within 14 Days of the receipt penalty notice.**

9.12. Engine Scrutineering Stipulations

- (a) At the time of scrutineering only the owner of the boat or one member of the crew is to remain with the boat inside the scrutineering area. It is this person's responsibility to strip the engine to the scrutineers desired state. It is also this person's responsibility to re-assemble the engine after scrutineering. No costs will be reimbursed after scrutineering.
- (b) No alcohol to be consumed in scrutineering area.

9.13. Gas jets or Rockets

Boats propelled by gas jets or rockets are not eligible to race. All propelling forces shall be directed in or against the water.

**SKI RACING AUSTRALIA (SRA) RULE BOOK
SEASON 2011 – 2012**

9.14. Fuels

Ski Racing Australia will only allow the use of commercially available unleaded fuels that are MTBE free. Ski Racing Australia will allow the use of Low lead Avgas that is MTBE free.

Only commercially available automotive unleaded pump fuel may be used. Commercially available low lead Avgas may be used. The use of any Race specific, (whether leaded or unleaded), unleaded, leaded or any other types of fuels that contain MTBE, known as Methyl Tertiary Butyl Ether, or any fuel additive or octane booster that contains MTBE, known as Methyl Tertiary Butyl Ether is banned. (For example; VP fuel, Unical, Elf or Sonoco fuels or additives that contain MTBE are banned) The use of an illegal fuel that contains MTBE will result in the cancellation of SRA Membership.

10. COMPETITION AREA

10.1. Course

- (a) A set course and distance, with a minimum depth of 2 metres, must be provided for all SRA sanctioned events. A competition area, course, and alternative position of buoys, location of lap buoys, starting buoys, beaches and finishing buoys will be clearly defined by the Officials. A minimum of 2 buoy turns is compulsory at Australian Speed and Marathon Championships. These will be clearly outlined to the competitors in writing 24 hours before the event and/or at a briefing by the Race Controller prior to the start of the event. The number of laps, if more than one, and the finish line, shall also be clearly designated at the briefing prior to the start.
- (b) It is desirable that a scale map of long distance courses be made available to competitors.
- (c) The course shall be marked by buoys, moored vessels or permanent seamarks. All markers shall be passed on the outside, unless otherwise directed at the briefing.
- (d) All courses shall run in an anti-clockwise direction. Boats will travel in anti-clockwise direction unless otherwise directed.
- (e) Each course buoy should be clearly and adequately marked to ensure a safe Racecourse. Guidelines for desirable dimensions of turn and course buoys are as follows:-
Turn Buoys - a minimum of 75cm in height and 45cm in diameter.
Course Buoys - a minimum 50cm high and minimum 30cm in diameter. All buoys to be constructed and laid so as not to create a hazard.
- (f) Any buoys marking safety hazards shall be clearly distinguishable for the course buoys. All buoys shall provide maximum visibility.

**SKI RACING AUSTRALIA (SRA) RULE BOOK
SEASON 2011 – 2012**

- (g) Should a mark be absent from its proper place during a heat or race, the Officials may replace the mark or substitute one therefore, at the discretion of the Committee.

10.2. Buoy Colour Code

- (a) Orange — Centre Course Markers.
White — Outside Course Markers
Large Orange Buoys — Course Turn Buoys.
Yellow — Safety Hazard or Clearance Buoy.
Black and White or Black and Yellow Chequered — Finish Buoy/s.
- (b) It is recommended that all course buoys be fluorescent colours.

11. CONDUCT IN COMPETITION AREA

11.1. Governing Rules

- (a) All competitors must be conversant with the official Ski Racing Rules.
- (b) The Governing Body Regulations concerning power boats will be adhered to at all times during all events by drivers and skiers. In ocean contests, the Rule of the Road at Seas will be observed. Boats and skiers must proceed around the course as indicated at the briefing and must pass on the correct side of all course marker buoys. Failure to comply with these regulations, or any of the Ski Racing Rules may result in disqualification, except in the case of rules where a lesser penalty is indicated, but a boat shall not be disqualified if wrongly compelled to do so by another boat, or where the majority of the event Judges are satisfied that a rule has been breached for safety reasons **ONLY** and that the team breaching the rule has gained no advantage.
- (c) No refuelling allowed in the water at any SRA sanctioned event.

11.2. Safety Precautions

- (a) All possible safety precautions to be taken.
- (b) No competitor shall be allowed to compete or to continue to compete if, in the opinion of the Safety Officer and two-thirds of the event Judges, by continuing to compete would be a danger to that competitor or other competitors in the event. During the competition, the Safety Officer may, at any time, request the Chief

**SKI RACING AUSTRALIA (SRA) RULE BOOK
SEASON 2011 – 2012**

Judge to halt the event for a poll of the Judges in regard to the competitor's actions or condition. Whenever practical, the advice of a doctor should be obtained.

- (c) Any participant hospitalised or sustaining any injury during the racing season, which in the opinion of any or all of the following Officials, the Safety Officer, the Chief Judge or the State Ski Racing Committee, could have an effect on the competitor or others safety, must, if requested to do so by any or all of the above, present a Doctor's release, in writing, to that Official/s prior to continuing to race for that or the following season.
- (d) Where a medical certificate is required to allow a participant to compete following an injury or illness, the medical certificate is too clearly state that the participant is fit to resume racing at speed. Failure to produce a medical certificate clearly stating this will result in the participant not being allowed to compete.
- (e) All boat crewmembers must wear spectacles if eyesight requires spectacles under normal circumstances.

11.3. Breakdown or Equipment Failure

In case of breakdown or equipment failure outside assistance is permissible, providing that no infringement or hazard is created to any other competitor.

11.4. Skier Entering Boat during Competition

Skiers may get into stationary boat during event in case of distress, boat breakdown, refitting of skis, with no penalty.

11.5. Fastening of Towline or Handle/s

- (a) Skiers are strictly prohibited from fastening their towline or the handle of the towline to the body in any way whatsoever.
- (b) The skier towline may consist of a front handle and 2 for use behind the body. Handle at front of the body may be different size to the rear handle/s. Both rear handles shall be of the same diameter, shape, length, texture and holes pacing for attachment.
- (c) There shall be NO means of mechanically holding the rear handles together. There shall be NO means of fastening to the body or ski suit.

**SKI RACING AUSTRALIA (SRA) RULE BOOK
SEASON 2011 – 2012**

11.6. Connection to Tow Line

The skier must always have at least one hand on his towline.

11.7. Entries

- (a) Entries for Ski Racing events will only be accepted on the prescribed official Entry Form and is to be lodged as advertised. For the Ski Racing Australia Speed and Marathon Championships, the entry is to be lodged to the organising committee (address is on entry form) four (4) weeks prior to the event. Late entries will be accepted no later than practice day. A late entry fee of 50% of the full entry fee will apply.
- (b) The Ski Race Committee reserves the right to refuse any entry.
- (c) Notification of withdrawal of an entry must be within one hour before official draw to be eligible for refund.

11.8. Order of Contestants

Before the start of each event, the entry list shall be closed and the order of contestants shall be made by random draw and contestants notified. No change in this order is permitted except for withdrawals. As each event starts, the order shall be announced and thereafter any contestants who fail to be in starting order and in condition to compete, shall not be allowed to start. However, for an acceptable reason they are unable to start after word “Go” they may leave as soon as possible whilst still retaining original start time.

11.9. Official Start Method

- (a) Official Start Method will be determined by the Ski Racing Committee methods selected, these will take into consideration safety factors in relation to location, beach and tide conditions on the day of the event. Methods considered will be:-
 - 1. Grid start/s with separate timing for each group.
 - 2. Simultaneous mass start.
 - 3. Time trial - interval starts.
- With:-
- 1. Beach Start
 - 2. Deep Water Start
 - 3. Pole Boat Start
- (b) Starter - An Official with reasonable experience of water ski racing. Will be appointed and briefed by the Chief Judge in consultation with the Race Controller.

**SKI RACING AUSTRALIA (SRA) RULE BOOK
SEASON 2011 – 2012**

- (c) All start procedures other than off the bank, will have the start boat moored, as well as fixed bouys to indicate a start line, along with a courtesy or dropin bouy / bouys at approximately 100 metres (300ft) prior to the start line.

11.10. Grid Start

Similar to mass start, but each group must move to the start line within the time nominated at the briefing.

11.11. Simultaneous Mass Starts

All contestants start on the same grid or line. See Rules 16.01 & 16.02.

11.12. Ski Racing Events - Interval Starts.

The start will be as directed by the Starter for the event, either timed intervals or a uniform time start. The Starter will count down each contestant or contestants. The word “Go” will signify the commencement of timing unless some loud, audible device is used. The Starter will call push out at 10 seconds, motors must not be started till “Go” and any boat whose motor is started before “Go” will have one minute added to its time. The methods decided upon will be used for all boats in the event. Starting Judge shall have control of warming of motors after start of event.

11.13. Briefing of Competitors

- (a) The organisers must hold a pre-race briefing during which fullest possible details must be given concerning navigation, course and safety of the competition, including the dropping off area at the conclusion of the race or issue a detailed briefing sheet.
- (b) Boat drivers and observers must attend compulsory briefings or will not be allowed to start.

11.14. Start

- (a) In the case of a fall in the start area the boat must idle and turn slowly and return to the skier for a pick up. Wide fast turns may result in disqualification.
- (b) Safety flag not required in marked Start Area.

**SKI RACING AUSTRALIA (SRA) RULE BOOK
SEASON 2011 – 2012**

- (c) In the event of a race having to be stopped, only boats which took their grid positions for the event will be allowed to restart.

11.15. Tow lines

Towlines must be fed from the boat at the start of an event.

11.16. Whipping of Skier/s and Unsuccessful Starts

- (a) Boats may whip a skier or skiers out during the start, however, excessive swerving greater than 45 degrees from the mean course direction shall incur a penalty if impeding other competitors.
- (b) Boats must not whip a skier out during mass type starts or lane racing.
- (c) If a successful start is not made following two attempts to start, the competitor must either withdraw from the event or move well away from the start area.

11.17. Lifting of Boats

No lifting boats at start of event.

11.18. Drivers to Look Forward

- (a) The driver must keep his attention ahead of the boat at all times.
- (b) Boat drivers must look ahead at start of race — observer to watch skier/s take off, however, driver may glance back.

11.19. Observers Duty

- (a) Occupants of boat must remain in cockpit at all times, i.e. observer's feet to remain on floor of boat whilst putting weight on foredeck.
- (b) In tunnel or tunnel deck hulls, observer's feet must not go past the driver's seat on take off and must remain in observer's cockpit.
- (c) Observers must keep the skier under observation at all time during his participation in the event.
- (d) Observers will remain in their seats at all times whilst pulling a skier after reaching a plane.

**SKI RACING AUSTRALIA (SRA) RULE BOOK
SEASON 2011 – 2012**

11.20. Skiing Position/A Fall

- (a) A Skiing Position is defined as the skier's weight is wholly supported by the ski or skis and he has possession of the towrope.
- (b) A Fall is defined as accomplished at the time when a skier loses possession of his ski, the towline, or is not maintaining a skiing position, that is, the skier's weight is wholly supported by the ski or skis and he has possession of the towrope.
- (c) In the case of a fall of a skier/s, the driver must immediately slow the boat and the observer must raise the safety flag.
- (d) When picking up a fallen skier, you must slow down, yield right of way to oncoming boats, then turn either direction, whichever is safer and come back along their line. Ski line must be kept as parallel to the course as possible.
- (e) A fallen skier is allowed to make physical contact with the boat and crew to enable the replacement of equipment. At all times whilst such action is being carried out, the motor of the tow boat will be dead or in neutral, i.e. propeller not rotating. The safety flag must remain visible until the boat is under way and the skier/s is in proper skiing position.
- (f) A driver or observer shall acknowledge the safety or medical flag on a race boat and the downed skier by putting his hand up. Failure to do so may result in a penalty.
- (g) Competitors are required to fill out a Falls Report and, where applicable, a fall and an Accident Report at all events.

11.21. Passing in a Distance Race

- (a) Passing shall be either side unless specifically stated otherwise at briefing.
- (b) A boat or team shall not force a passage between other team/s or a team and course or hazard buoy.
- (c) It is obligatory that all turns shall be marked by buoys, moored vessels or permanent seamarks. All markers shall be passed on the outside. No changing of lanes is permitted from within 100 metres of the turn buoy or mark, this distance to be clearly shown by a 100 metre buoy or marker, until the skier rounds the buoy and attains a straight line on the natural course. Minimum distance of 2 metres between competing boats after the start.

(c-1) If the outside boat believes the inside boat has turned in an unnecessarily large arc causing the outside boat loss of time or putting that boat in danger (river bank

**SKI RACING AUSTRALIA (SRA) RULE BOOK
SEASON 2011 – 2012**

etc.), the outside boat may report to the Chief Judge bad or dangerous driving or bad sportsmanship.

- (d) When taking a turn, the boats on the outside must leave room for teams on the inside.
- (e) An overtaking boat must not cut in until the skier is 100 metres ahead of the boat being overtaken.

11.22. Passing Applicable to All Events Unless Noted Otherwise

- (a) Skiers must ski to the outside of each turn, course or hazard buoy.
- (b) A fallen skier may be passed on whichever side is deemed to be the safest. The passing driver or observer shall acknowledge sight of a fallen skier by raising a hand.
- (c) For a single skier race, the skier must remain in the wake of the towing boat for the entire race.
- (d) When more than one skier is being towed in a race, skiers must ski in the wash or within two metres of the wash at all times. Two skiers may not ski on the same side of the boat outside the wash.

Penalty - Disqualification.

- (e) Boats shall not follow closer than 100 metres directly behind any skier except when overtaking, in which case it is imperative that the driver should keep his boat in a different line than the preceding one. **Penalty - Disqualification.**

11.23. Failure to Complete Course

Any boat not completing course i.e. missed turn buoy, will not be given a finishing time. Any boat that misses a course buoy/s will be given a penalty relative to the infringement. However, should a missed buoy/s be recovered before the completion of the same lap, course will be deemed as completed. Missed safety buoys must **NOT** be recovered.

11.24. Skiers to use Same Number of Skis

Skiers in speed events must complete the course on the same number of skis they start with, however, damaged or lost equipment during the race may be replaced.

**SKI RACING AUSTRALIA (SRA) RULE BOOK
SEASON 2011 – 2012**

11.25. Finish

- (a) The finish of the ski race shall be determined by the skier.
- (b) Skiers must be in skiing position when crossing the finishing line or as long as a skier is attempting to regain a skiing position and in the process crosses the finish line and eventually attains skiing position within a reasonable distance.

11.26. Drop-off area and Use of the Chequered Flag

- (a) The drop-off area for a ski race will be determined by the Officials prior to the event and announced at driver's meeting. Skiers must hang onto handles and must drop off in the areas indicated.
- (b) In a race where the chequered flag is not being used to denote the finish of the race, any boat completing more than the prescribed number of laps shall be disqualified.

12. SKI RACING EVENTS

12.1. Definition

These events are generally those which “compete against the clock”, and may consist of timed events or first past the finishing line events over set distances or laps, varied as required by the Ski Racing Committee in the matter of number of skiers, class of boats, types of skis used and the courses to be covered.

13. MARATHONS

13.1. Course and Order of Skis

Marathons will be divided into six sections or laps.

The start method will be grid or interval starts and the sections will be as follows:

1 st Section	Single Ski with Fin
2 nd Section	Double Ski with Fins
3 rd Section	Single Ski without Fin
4 th Section	Double Skis without Fins
5 th Section	Freeboard Ski
6 th Section	Paling/Plank

**SKI RACING AUSTRALIA (SRA) RULE BOOK
SEASON 2011 – 2012**

13.2. One Skier Only for Event

One skier will ski for the whole of the event, and any number of falls allowable. Competitors may enter only one marathon.

13.3. Changeover Area and Course

- (a) When skiers in the marathon have completed the first section or lap they will enter the changeover area to change or fit additional ski/s as so desired. Pick up boats will collect discarded skis.
- (b) Skiers must enter nominated changeover area and are required to sink into the water at each changeover. Skier is not to be in a skiing position.
- (c) Marathon laps at organiser's discretion and competitors will complete one lap each section as specified above.
- (d) Only six (6) scrutineered skis may be used by a skier in marathon events, of which five (5) may be carried in the boat.

13.4. Finish Time at Judges Discretion

Skiers must finish within a reasonable time, this time to be at the discretion of the Chief Judge.

13.5. Australian Marathon Championships

The Marathon course layout will be set to a 5km course lap and competitors will complete one lap for each section as specified in 13.1

14. AUSTRALIAN SPEED & MARATHON CHAMPIONSHIPS

14.1. Race Committee

- (a) The Race Committee shall at least consist of the following Officials:
 - i) Race Controller
 - ii) Ski Racing Technical Director
 - iii) Safety Officer
 - iv) Chief Scrutineer
- (b) In Events and Championships, the Race Committee will set the course, which shall meet with the Chief Judge's approval, alterations to the course must be made to the Chief Judge's approval, provided notice of such alterations is given to each competitor before the start of the event.

**SKI RACING AUSTRALIA (SRA) RULE BOOK
SEASON 2011 – 2012**

- (c) On a closed course, the Committee in control shall see that the course is clear of all traffic for a period covering the race (or heat) for five minutes before the start and five minutes after the completion of such event. The Championship course shall be laid down, ready for inspection, at least one hour prior to the Official starting time of the Championship for inspection and approval of the Chief Judge or his/her representative. This shall be extended to one day prior to the start of events for the Australian Speed and Marathon Championships.
- (d) The State hosting the Championships shall see that the course and the competitors do not contravene any of the Regulations as laid down by any Government or Local Authority.

14.2. Rescue Services

It is a minimum requirement of SRA that an on Duty Paramedic/Doctor must be in attendance at all SRA Sanctioned events. That person must have life saving medication and be qualified and approved to administer these medications. They must have the ability to contact local medical/rescue services. They must have appropriate current liability insurance cover.

14.3. Communications

It is desirable that the Organisers ensure communication be maintained between all course Officials and course boats.

14.4. Events and Times for Australian Speed & Marathon Championships

- (a) These events are generally those, which compete against time and will be run over a time duration as follows:-

Open Men	40 mins + 1 lap	Open Women	30 mins + 1 lap
19 - Under 25 Men	30 mins + 1 lap	19 - Under 25 Women	25 mins + 1 lap
25 - Under 30 Men	25 mins + 1 lap	25 - Under 30 Women	25 mins + 1 lap
30 - Under 40 Men	20 mins + 1 lap	30 - Under 40 Women	15 mins + 1 lap
40 - Under 50 Men	15 mins + 1 lap	40 - Under 50 Women	15 mins + 1 lap
50 & Over Men	15 mins + 1 lap	50 & Over Women	15 mins + 1 lap
16 - Under 19 Boys	30 mins + 1 lap	16 - Under 19 Girls	25 mins + 1 lap
13 - Under 16 Boys	25 mins + 1 lap	13 - Under 16 Girls	25 mins + 1 lap
10 - Under 13 Boys	15 mins + 1 lap	10 - Under 13 Girls	15 mins + 1 lap
0 - 9 Boys	10 mins + 1 lap	0 - 9 Girls	10 mins + 1 lap
Social Men	25 mins + 1 lap	Social Women	20 mins + 1 lap
Engine Classes	25 mins + 1 lap		
Disabled Class	15 mins + 1 lap		

**SKI RACING AUSTRALIA (SRA) RULE BOOK
SEASON 2011 – 2012**

- (b) In Australian Speed and Marathon Championships one entry constitutes a class or division.
- (c) Super Class - NOT IN SKI RACING AUSTRALIA SPEED AND MARATHON CHAMPIONSHIP EVENTS.

14.5. Restrictions Applicable to Australian Speed and Marathon Championships

- (a) In Australian Speed & Marathon Championships a skier may nominate in his or her age division, Open, Social Men or Women and one Engine class only.
- (b) The Speed Championships will be conducted in all Divisions and Classes subject to entries.
- (c) All drivers and observers entering in the Australian Speed and Marathon Championships must hold an ski racing drivers or observers licence as applicable to entry.
- (d) Qualifications for drivers and observers to compete in the Australian Championships are that they must have competed in three mass start circuit type sanctioned races.

14.6. Additional Rules

Additional rules to be advised to competitors in writing 7 days before event. One skier per boat. All winners will be called Australian Division or Class Champions respectively.

14.7. Events Stopped with less than 50% completed

Where an event is stopped at a distance of less than 50% of the race, it must be re-run.

14.8. Eligibility to Enter Australian Speed and Marathon Championships

Any competitor wishing to enter the Australian Speed and Marathon Championships must have competed in major sanctioned State event or a State Ski Racing Championship.

14.9. Appointment of the Chief Judge, Assistant Chief Judge, Calculator and Judges

Nominations for Chief Judge, Assistant Chief Judges x 2, Calculator and Judges shall be called for from each State. The SRA Director, in consultation with the Judges Coordinator,

**SKI RACING AUSTRALIA (SRA) RULE BOOK
SEASON 2011 – 2012**

shall consider the nominations and select the above positions. The SRA Director or the Judging Coordinator shall advise the selections to the applicants.

14.10. Appointment of Adjudicator

The Adjudicator will be a serving State Ski Racing Director and will be appointed by the SRA Director for the period of the Australian Speed and Marathon Championships only.

Duties: To adjudicate on complaints from competitors and to adjudicate solely on intent of Ski Racing Rules.

14.11. Team Captains

Each State shall select a representative whose duty it will be to contact the Chief Judge on all matters concerning all his/her State's competitors. The name of this representative shall be given to the Chief Judge 24 hours prior to the start of the event.

14.12. Lane Racing

Lane Racing is to be conducted in accordance with the rules approved by the SRA Board. Refer to Lane Racing Rules attached to this Rule Book, as amended and approved by the SRA Board.

15. RELAYS AND CLUB RACING

15.1. Relays and Club Racing

To be conducted in accordance with the Lane Racing Rules, as approved and amended by the SRA Board.

**16. CIRCUIT RACING (GRAND PRIX TYPE RACING)
(INTERNATIONAL WATER SKI FEDERATION)**

16.1. Starting Distance

All starts are only allowed if a distance of at least 10 metres on either side of each competing boat is allowed for. It is recommended that the distances between the starting line and the first turn is 2.5kms.

SKI RACING AUSTRALIA (SRA) RULE BOOK
SEASON 2011 – 2012

16.2. Simultaneous Mass Start Procedure

- (a) For a simultaneous mass start, a 5 minute signal shall be given by raising the National flag together with a green flag on the moored start boat or dock In sight of the skiers and boat crew. The 30-second signal shall be given by lowering the green flag. Skiers may then enter the water from their boats which may take up the slack in the towline. The start will be signalled by the lowering of the National flag and skiers must not be in a skiing position until the start is signalled. Boats must not be over the start line prior to the lowering of the National flag. The start line will be indicated by placing a buoy or buoys in line with the stern of the moored start boat. **Penalty - 1 minute. Rule 5.6(b).**
- (b) When the starting procedure is stopped the red flag must be raised during the interruption. The new start procedure shall normally be of 3 minutes instead of 5 minutes. The new 3-minute start shall follow the normal procedure.
- (c) In the event of a race having to be stopped, only boats which took their grid positions for the event will be allowed to restart.
- (d)
 - (i) Following a red flag situation the Chief Judge will decide whether the race will be a continued race or an entire new race.
 - (ii) If the restart is a continuation of the original race, the number of completed laps prior to the red flag, will be carried forward to the restarted race and the pole positions will be determined by the placing as of the last completed lap prior to the red flag. The team causing the red flag, and teams who have retired from the race, are not allowed to restart the race whether the restart is a continuation of the original race or a new race. Exception - Weather conditions.

16.3. Timing

Timing will be accurate to at least one hundredth of a second, this precision holding good as well for departure as for arrival of a skier.

16.4. Placing to be determined by the Skier/s Time

Places in the competition shall be determined according to the skier times made, after addition of the penalties, if any.

**SKI RACING AUSTRALIA (SRA) RULE BOOK
SEASON 2011 – 2012**

16.5. Finish

- (a) Races shall finish when the leader crosses the finish line between two specified points (buoys, boats, etc.) and the following competitors shall finish on completion of the lap on which they are skiing. A maximum of 15 minutes will be allowed after the leader finishes for other competitors to cross the finish line.
- (b) When the leading team completed the designated time for the event, the blue flag will be displayed to indicate the leader is on his/her final lap. The Chief Judge has the discretionary power to have the blue flag displayed to the leader, up to a maximum of 20 seconds prior to the designated time of the race. On completion of the leading team's final lap the black and white chequered flag will be raised. All the following skiers will finish on the chequered flag. A maximum of 15 minutes after the leader crosses the line will be allowed for other competitors to complete the race.

16.6. Turns, Passing and Changing Course

It is obligatory that all turns shall be marked by buoys, moored vessels or permanent seamarks. All markers shall be passed on the outside. No changing of lanes is permitted from within 100 metres of the turn buoy or mark, this distance to be clearly shown by a 100 metre buoy or marker, until the skier rounds the buoy and attains a straight line on the natural course. **Penalty Rule 5.5(a).**

16.7. No Crowding or Forcing a Passage

- (a) When taking a turn, the teams on the outside must leave room for teams on the inside. **Penalty Rule 5.5(a).**
- (b) A boat or team shall not force a passage between other teams or a team and course or hazard buoy. **Penalty Rule 5.5(a).**

16.8. Distance between competing Boats

Minimum distance of 2 metres between competing boats after the start.

16.9. Procedure to be followed after a Fall

In the case of a fall of a competitor, the driver must immediately stop the boat, the observer must display the **bright**/flame orange flag. The driver will turn to pick up the skier without interfering with the progress of the race. In picking up a fallen skier, the driver must give right of way to oncoming boats and then turn in whichever direction is safer. A fallen skier is allowed to make physical contact with the boat and crew to enable the replacement of

**SKI RACING AUSTRALIA (SRA) RULE BOOK
SEASON 2011 – 2012**

equipment. At all times whilst such action is being carried out the motor of the towboat “will be dead or in neutral, i.e. propeller not rotating”. **Penalty Rule 5.5(a).** The **bright/flame orange** flag must remain visible until the skier is in proper skiing position. **Penalty Rule 5.5(b).**

16.10. Distance required before Boat can Cut-in

An overtaking boat must not cut in until the skier is 100 metres ahead of the boat being overtaken. **Penalty Rule 5.5(a).**

16.11. Distance required when following a Skier

Boats shall not follow closer than 100 metres directly behind any skier except when overtaking, in which case it is imperative that the driver should keep his boat in a different line than the preceding one. **Penalty Rule 5.5(a).**

16.12. Closed Circuit Racing

In closed circuit racing, the Jury must state at the briefing and display on a blackboard the manner of passing other competitors. The designated manner of passing other competitors must be complied with. A fallen skier may be passed on whichever side is deemed to be the safest. The passing driver or observer shall acknowledge sight of a fallen skier by raising a hand. **Penalty Rule 5.5(b).**

16.13. Competitors to Give Way

Refusing to give way to other competitors is strictly prohibited. **Penalty Rule 5.5(a).**

16.14. Required Flags and their Meanings

FLAGS The following flags are required:

- (a) **NATIONAL**
The National flag may be used as a starting flag - dimensions 100 x 100 cms.
- (b) **GREEN**
Pre-start and identifying flag for judges, safety and rescue boats - dimensions 50 x 50 cms.
- (c) **YELLOW**
Caution. Judges and safety boats will raise the yellow flag when a skier has fallen, when a skier is in the water, or in any other case of interference after the National flag has started the race - dimensions 50 x 50 cms.

**SKI RACING AUSTRALIA (SRA) RULE BOOK
SEASON 2011 – 2012**

- (d) **RED**
Stop the race. The judges and safety boats will raise the red flag to stop the race - dimensions 100 x 100 cms.
- (e) **BLACK**
Disqualification. The black flag is used to notify a competitor that he has been disqualified and that he must retire from the race. When the black flag is shown, the number of the team being disqualified should be displayed in figures not less than 300mm high at a point designated by the Chief Judge - dimensions 100 x 100 cms.
- (f) **BLUE**
One lap to go for leading boat - dimensions 100 x 100 cms.
- (g) **CHEQUERED**
Finish. The chequered flag indicates the end of the race - dimensions 100 x 100 cms
- (h) **FLUORESCENT PINK & GREEN**
Where Divisions or Classes are run together at Australian Ski Racing Championships, a second finish flag coloured fluorescent pink and fluorescent green shall be used as indicated to competitors at the race briefing.
- (i) **WHITE**
The white flag will be used to designate **return to pits**.
- (j) **JUDGE'S BOATS**
Each judge's boat must continuously fly a green flag for identification; they shall also carry yellow, red and black flags on board. The red and the black flags can only be used after communication with the Chief Judge, and on his/her instructions.
- (k) **SAFETY & RESCUE BOATS**
The safety and rescue boats must continuously fly a green flag for identification.

17. WORLDS COMPETITION

17.1. Selection of Australian Team Members to compete at World Water Ski Racing Championships

- (a) The Australian Ski Racing Open Team shall consist of 3 men and 3 women. The Australian selectors have the right to select an additional non-skiing reserve in each of these divisions.
- (b) A Junior Team shall also be selected consisting of 2 boys and 2 girls (no reserves). The maximum age of any skier participating in the Junior World Championships is

**SKI RACING AUSTRALIA (SRA) RULE BOOK
SEASON 2011 – 2012**

16 years as at 31 December in the year preceding the Championships. This means that the last year of eligibility of the skier is the year in which he/she has his/her 17th Birthday. Juniors will not score points for the Teams Shield.

- (c) Formula 2 competitors, selected as per IWSF requirements. 3 men and 3 women from each Federation will be permitted to compete in Formula 2 Competition at World Championships. Formula 2 Men's race will compete in the same event as the Men's race and the Formula 2 Women will compete in the same event as the Women's race. Only skiers who have not placed in the first three places in any open World Championship Race or the first three places overall, at the last three World Championships are eligible to compete in Formula 2. Skiers must qualify by competing in the Formula 2 class in the series of events from which selection is made for their Federation. The Australian selectors have the right to select an additional non-skiing reserve in each of these divisions.

17.2. Skier Eligibility to Compete at the World Water Ski Racing Championships

A Federation may select its team in any manner it desires; however, each team member must be a citizen or applying for citizenship of the country, which the Federation represents. In case of doubt as to the nationality of a competitor, the judges normally will refer to his passport. If a skier does not have a passport from the country for which he is skiing, he must prove residence in the country for at least five years and membership of the Federation. Each Federation shall certify to the judges that all members of its team meet these requirements.

17.3. SRA Selection Policy

All crew/s wishing to compete at the World Water Ski Racing Championships, will be required to abide by the SRA Selection Policy and shall sign an intention to compete.

**SKI RACING AUSTRALIA (SRA) RULE BOOK
SEASON 2011 – 2012**

18. Ski Racing Australia Code of Conduct For Members

18.1 All members of SRA, whether they be Competing Members, Officials, Supporters or simply Social Members, are required by the Constitution (Section 8) to set a minimum standard of conduct and not engage in non-social behaviour, not only at sanctioned events, whether held under the auspices of SRA itself or a constituent body.

CONDUCT BY MEMBERS

18.2 For the purposes of this rule a “social event” shall be deemed to be held under the auspices of the SRA whether it be formal or informal and is constituted by an informal gathering by Members as a consequence of a holding of an ski racing event, provided however that the timing of such a gathering was the result of a recent competition.

18.3 All Members are expected to exhibit a level of conduct which is socially acceptable. The term “socially acceptable” for the purpose of these rules, means that level of conduct which would be regarded as acceptable by a reasonable person, at social occasions. Those Members, who during the course of a social event, display behaviour which is not socially acceptable shall be at all times subject to disciplinary procedures in the event that the non-social behaviour results in action being taken by the Judiciary Committee, pursuant to Section 8 of the Constitution and/or these Rules.

LEVEL OF BEHAVIOUR

18.4 For the sake of clarity, “Non-social behaviour” shall for the purpose of these Rules, be deemed to include but are not limited to the following:-

- i. Indulging in irresponsible behaviour whilst intoxicated;
- ii. Creating a fracas;
- iii. Engaging in any aggressive or fighting behaviour of any nature whatsoever;
- iv. Bad language or swearing in the presence of other members of their guests;
- v. Exerting intimidating behaviour against other members or their guests;
- vi. Engaging in any assault against another member or his or her guest;
- vii. Indulging in behaviour which causes or has the potential to cause injury to a third party as a consequence of either reckless behaviour or failure to exercise a proper duty of care.
- viii. Publishing any offensive or insulting material against another member in any electronic media (including online social networking) which has the potential to be available to the membership at large, whether or not at law such material would be regarded as libellous or defamatory in nature.

**SKI RACING AUSTRALIA (SRA) RULE BOOK
SEASON 2011 – 2012**

JUDICIARY COMMITTEE

- 18.5.1** For the purposes of dealing with any disciplinary proceedings, the National Board of Ski Racing Australia (“the Board”) shall constitute by way of appointment a Judiciary Committee, in accordance with Section 8.2 of the Constitution, which shall be empowered by the Board to hear and investigate any breach of conduct complained of and giving rise to the process as set out hereunder.
- 18.5.2** The Board shall use its best endeavours to appoint members to constitute the Disciplinary Committee in that State where the alleged breach of the Code occurred or whether the greatest number of members, both witnesses and persons cited for such breach, are resident.
- 18.5.3** Notwithstanding anything herein contained, the Board may, if it deems necessary, appoint a legally qualified person to assist the Judiciary Committee in the prosecution and investigation of the complaint.

PROCESS

- 18.6.1** The process of laying a complaint against a member is to be governed by Section 8.3 of the Constitution.
- 18.6.2** Where there is any apparent or perceived inconsistency between the process adopted by the Board or the Judiciary Committee in bringing disciplinary action against a member, the provisions of Section 8 of the Constitution shall prevail, and the Judiciary Committee appointed pursuant to that Section, shall use its best endeavours to ensure that it follows the procedures as laid down in Section 8.3 of the Constitution, having proper regard to the tenets of natural justice.
- 18.6.3** For the sake of further clarity, the procedures for initiating and prosecuting an alleged breach of discipline shall be by way of a Notice of Complaint in the format contained in the Schedule to these Rules, and shall in the first instance be directed to the Board for its consideration.
- 18.6.4** The Board shall in the first instance, determine whether the complaint is of such a serious nature that it should be referred to a disciplinary committee, and upon reaching that decision in the affirmative, shall attend to the appointment of a Judiciary Committee in accordance with the provisions under Section 8 of the Constitution.
- 18.6.5** Upon receiving written notification of his or her appointment, the Chairman of the Judiciary Committee, shall convene a meeting of the Judiciary Committee to settle the form of the Notice of Complaint against the member allegedly committing the breach of discipline.

**SKI RACING AUSTRALIA (SRA) RULE BOOK
SEASON 2011 – 2012**

- 18.6.6** The Judiciary Committee shall be entitled to carry out such preliminary investigations as it considers necessary, which may include the appointment of third parties to determine whether or not the making of a complaint is justified.
- 18.6.7** In preparing the form of complaint, the Board (“the Complainant”) shall serve upon the person named in the complaint (“the Respondent”) a Notice of Complaint, which shall include:-
- i. The nature of the offence
 - ii. The particulars of the offence
 - iii. The circumstances surrounding the offence
 - iv. The grade of penalty likely to be imposed.
- 18.6.8** The Notice of Complaint, in addition to the above particulars, shall provide the following information:-
- i. The Respondent shall be invited to respond to the complaint in writing within 21 days of the receipt by him or her of the Notice of Complaint.
 - i. The Respondent shall be notified of the date of the proposed hearing of the complaint by the Judiciary Committee at the time of service of the Notice of Complaint upon the Respondent.
 - ii. The Judiciary Committee shall, at the time of issuing the Notice of Complaint, also give notice to all witnesses of their requirement to attend the proposed hearing day.
- 18.6.9** The Respondent, upon receiving the Notice of Complaint, shall be entitled to respond in the following ways:-
- i. Admit the truth of the particulars of the complaint and be found guilty of the alleged breach of discipline as made out by the complaint; or
 - ii. Deny the allegations contained in the Notice of Complaint and seek a hearing of the complaint in accordance with the Constitution and the Rules.
- 18.6.10** In the event that the Respondent adopts the course referred to in sub-paragraph 18.6.9.(i), then the Chairman of the Judiciary Committee shall convene a time and place convenient to the Respondent, in respect of hearing submissions from the Respondent in relation to penalty, and shall determine the penalty, after such submissions have been heard.
- 18.6.11** In the event that the Respondent elects to defend the alleged breach of discipline in accordance with sub-paragraph 18.6.9.(ii), the Chairman of the Judiciary Committee shall convene a time, date and venue suitable to all participants in the hearing of the complaint, and shall adopt those procedures as set out in Section 8 of the Constitution and these Rules.

**SKI RACING AUSTRALIA (SRA) RULE BOOK
SEASON 2011 – 2012**

HEARING OF THE COMPLAINT

18.7 The hearing shall be conducted in the following manner:-

18.7.1 Any witness, when called upon by the Judiciary Committee, shall give oral evidence of the facts and circumstances surrounding the complaint;

18.7.2 The Respondent shall have the right of cross-examination of those witnesses giving oral evidence of the facts and the circumstances surrounding the complaint

18.7.3 The Respondent shall give evidence of the facts and circumstances surrounding the complaint and in doing so shall be subject to cross-examination by any member of the Judiciary Committee.

18.7.4 The Respondent shall at the conclusion of the evidence, be entitled to either make an oral submission or a submission in writing as to whether or not the complaint has been proven. The Judiciary Committee shall retire to make a decision and will notify the Respondent as to whether that decision will be reserved and in writing or will be made extempore.

18.7.5 At the conclusion of the proceedings, the Judiciary Committee may :-

- i. Dismiss the complaint on the grounds that it has not been proven; or
- ii. Find the offence to have been proven; or
- iii. Impose a penalty at the time of the hearing; or
- iv. Indicate to the Respondent that consideration of the penalty to be imposed shall be reserved and notified to the Respondent in writing.

18.7.6 At the discretion of the Judiciary Committee, the entire proceeding may be minuted for the benefit of the Board and in relation to any appeal proceeding.

PENALTIES

18.8 The Judiciary Committee upon making a determination of penalty, shall be empowered to impose those penalties as set out in Section 8.3 of the Constitution in general terms, but more specifically, may impose the following penalties:-

- i) Admonishment (Grade 1 offence)
- ii) Warning (Grade 1 offence)
- iii) Disqualification from an event (Grade 1 offence)
- iv) Fine (Grade 2 offence)
- v) Removal of points gained by member, arising out of a competitive event where the complaint arose (Grade 2 offence)
- vi) Removal of points from all events where complaint arose (if applicable) (Grade 2 offence)
- vii) Removal of all points from all events to date (Grade 3 Offence)

**SKI RACING AUSTRALIA (SRA) RULE BOOK
SEASON 2011 – 2012**

- viii) Suspension from future competition – on to twelve months (Grade 4 Offence)
- ix) Suspension from membership – one to twelve months (Grade 4 offence)

18.9 Upon conclusion of the proceedings, the Respondent shall receive within seven (7) days, a Notice of Decision which will set out the findings of the Judiciary Committee (with reasons) and shall state the penalty or penalties imposed as a consequence of that decision.

APPEALS PROCEDURE

18.10 The Respondent, upon receipt of the Notice of Decision may make an appeal to the Board within fourteen days from receipt, for a review of the complaint on the following grounds:-

- i) The decision was against the weight of evidence, and/or did not comply with the tenets of natural justice; or
- ii) The severity of the sentence.

18.11 The Respondent shall be required within fourteen (14) days from the date of receipt of the Notice of Decision to lodge a Notice of Appeal setting out the matters referred to above, and shall be in the format contained the schedule to these rules.

NATURE OF APPEALS PROCEDURE

18.12 Upon receipt of a Notice of Appeal from the Respondent, the Chairman of the Board shall convene a special meeting by either telephone conference or at a venue to be determined by the Board to consider whether leave to appeal should be granted.

18.13 In considering whether leave to appeal should be granted, the Board shall be provided with all papers, documents, minutes, memoranda and other evidence which is to be made available by the Judiciary Committee so as to enable the Board to make an informed decision upon a review of the complaint.

18.14 Upon determining the issue of granting leave to appeal in the affirmative, the Board shall appoint an Appeals Committee which shall be constituted of members who have had no previous connection with the proceedings brought before the Judiciary Committee.

18.15 The Appeal Committee shall not be entitled to consider any material of any nature which has not been previously tendered to the Judiciary Committee as part of the proceedings relating to the complaint.

**SKI RACING AUSTRALIA (SRA) RULE BOOK
SEASON 2011 – 2012**

COMPLAINT PROCEDURES – COMPETITION

18.16 In the event of a minor infraction relating to the Code of Conduct on the part of a competitor member during competition, the procedures set out herein shall not be used but alternative procedures shall be adopted for any Grad 1 or Grade 2 offence, committed under the auspices of Ski Racing Australia.

SUMMARY JURISDICTION OF CONSTITUENT BODIES

18.17

- (i) Notwithstanding anything herein contained in this Rule, nothing shall delimit the SRA from delegating its disciplinary powers to a Constituent Body, in those cases where in its unfettered discretion, it considers that a particular breach of the Code of Conduct by a member or members, is of such a minor nature that it can be dealt with summarily by the Constituent Body in the jurisdiction in which the minor infraction occurred.
- (ii) Any such delegation of authority, as proposed by 18.17(i), shall be on the condition that the procedures invoked by the Constituent Body will be as similar as possible as those procedures adopted by SRA in the case of infractions of a serious nature. At all times, the Constituent Body will use its best endeavours to ensure that the tenets of natural justice shall apply at all times.

**SKI RACING AUSTRALIA (SRA) RULE BOOK
SEASON 2011 – 2012**

Formula 2 Rules, as per IWWF Rule book.

5.34 Formula 2 Rules. (IWWF Rule numbers)

- (a) Hulls – Minimum length of hull shall be 18 ft or 5.48 metres. See Rule 5.01.
- (b) This class is for single outboards only.
- (c) Standard low emission (CARB rated) engines manufactured in 2003 and onwards only. No modifications are permitted with the exception of nosecones and torque tamers. The manufacturer's original location for water pick ups must be maintained. No performance enhancing.
- (d) Engine capacity – Maximum manufacturers rating of 300HP as per **ISA** Rating schedule 28.
- (e) All engines must carry original manufacturer's model number, serial ID plates, stickers or tags. These will be located on the engine.
- (f) The upgrading of engines from their original year specifications will not be accepted.
- (g) The factory supercession of parts is acceptable.
- (e) Standard gear box available for the engine model only.
- (f) Must run standard manufacturer's exhaust system.
- (g) All engines must have operational forward, neutral and reverse gears controlled from the cockpit.
- (h) Steering – cable, hydraulic or dual ride guide steering is acceptable but must meet the requirements of steering rule 5.08
- (i) No mechanical means of height adjustment for the motor whilst in motion.
- (j) Original factory Engine Management System to remain in place and unaltered.
- (k) No steering or throttle is to be wireless.
- (l) F-2 class shall be restricted to commercially available unleaded pump fuel. No avgas, racing fuel or octane boosters.
- (m) All engines will be inspected and sealed by the organizing committee prior to the competition.
- (n) All engines competing in F2 will be technically inspected after each race and at the completion of the competition.

**SKI RACING AUSTRALIA (SRA) RULE BOOK
SEASON 2011 – 2012**

Amendments Page

List of Rule Changes and amendments in new rule book 2011 - 2012

List of the rule numbers that have changed or been adjusted from 2010 - 2011 season book. All changes have been put in red in the rule book.

3.7 (g)

6.3 (a) *First Year novice* - is open to skiers in their first season of racing having never competed in any sanctioned **one-up** event. A skier can only ski in First Year novice for one season. **One up removed**

6.7 **6.10 (d)** **6.10 (g)** **6.11 (d)** **6.14(a) (d)**

7.16 (b) **7.24 (a)** **7.27** **7.32 (a)** **7.39 (c) (f) (g)**

7.26(c) Rule was 3mm in rule book 26th July 04 edition 1.4 and Rule Book 18th Aug 03 edition 2

8.8 (a) **8.12 (c) (g)** **8.13 (c) Deleted**

9.1 All New **9.2 (a)** **9.6** **9.7 (d)** **9.8 (d) (e)**

9.9.2 (k) **9.10 (g) drawing removed** **9.11 (b) (d) (f) (h)**

14.2 **14.4 (a)**

16.9

18 All updated

F2 Rules (d)